

Monoblock directional control valve - double solenoid control

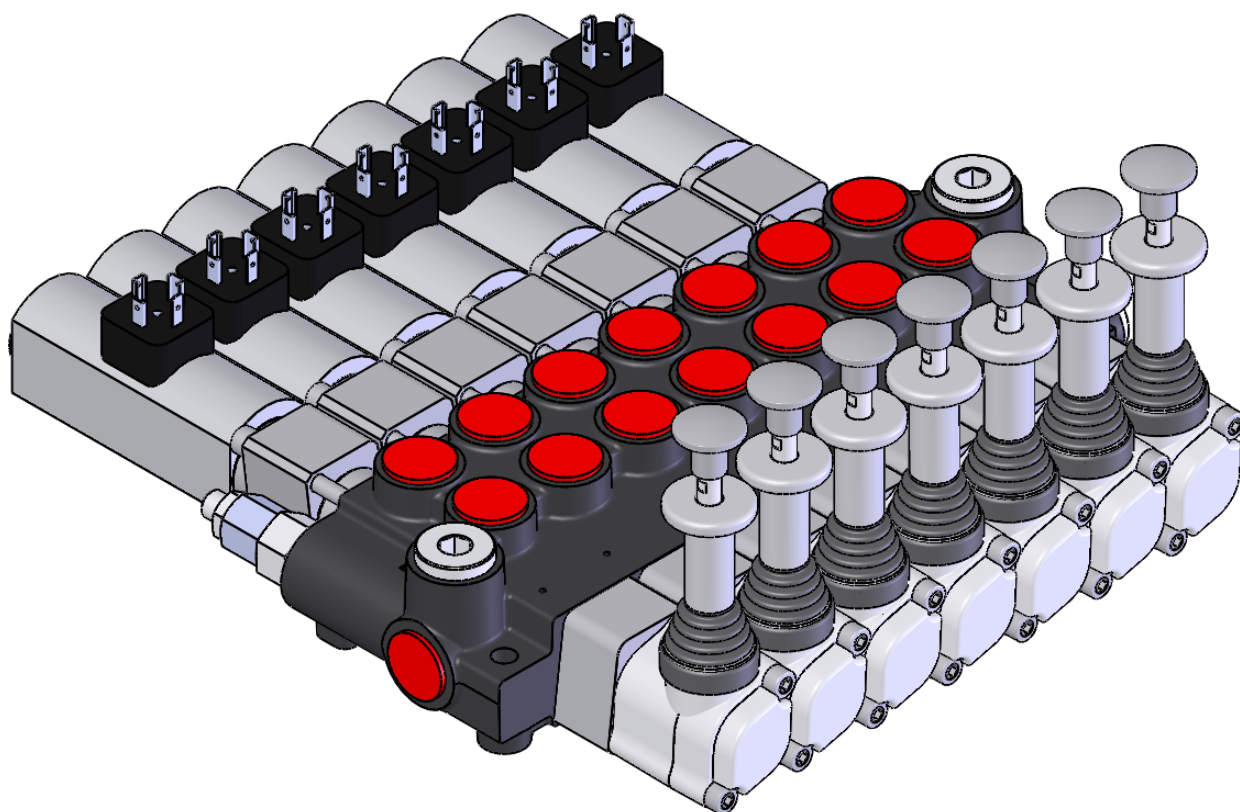

Model Z50A1ESD

Z50A1ESD is the new generation of our monoblock directional control valves - solenoid operated Z50ES and also offers perfect choice whether you are designing a new system or just simply trying to get more out of your current system. With two special spools and option of having 7 spool valve body configuration these valves can meet the specific needs of your application. Its new feature is that the control is achieved by double solenoid with spring return to neutral position, available with emergency manual override. Due to it's relation to the eariler Z50ES the bodies are interchangeable requiring only spool seals change.

Standard features

- Hydraulically balanced, hard chrome plated spool
- Fitted with main pressure relief valve and a load check valve
- Lever system which can be installed both up and down
- Flow capacity of 50 l/min
- In neutral position both work ports are blocked and the pump unloads to tank

Max. flow		50 l/min	<i>13.2 gpm</i>
Operating pressure (max.)	at port P	250 bar	<i>3600 psi</i>
	at work ports A and B	300 bar	<i>4300 psi</i>
Back pressure (max.)	outlet port T	20 bar	<i>150 psi</i>
Internal leakage (standard) A(B)> T	p = 100 bar	18 cm ³ /min	<i>1,1 in³/min</i>
Fluid		Mineral base oil	
Fluid temperature	with NRB (BUNA-N) seals	from -20°C to 80°C	<i>from -4°F to 176°F</i>
	operating range	from 15 to 75 mm ² /s	<i>from 15 to 75cSt</i>
Viscosity	min.	12 mm ² /s	<i>12 cSt</i>
	max.	400 mm ² /s	<i>400 cSt</i>
Max. contamination level		-/19/16 – ISO 4406	<i>NAS 1638 – class 10</i>
Ambient temperature for working conditions		from -40°C to 60°C	<i>from -40°F to 140°F</i>
Spool stroke		3,2 mm	<i>0,12 in</i>
Actuating force		<100 N	<i><25 lbs</i>

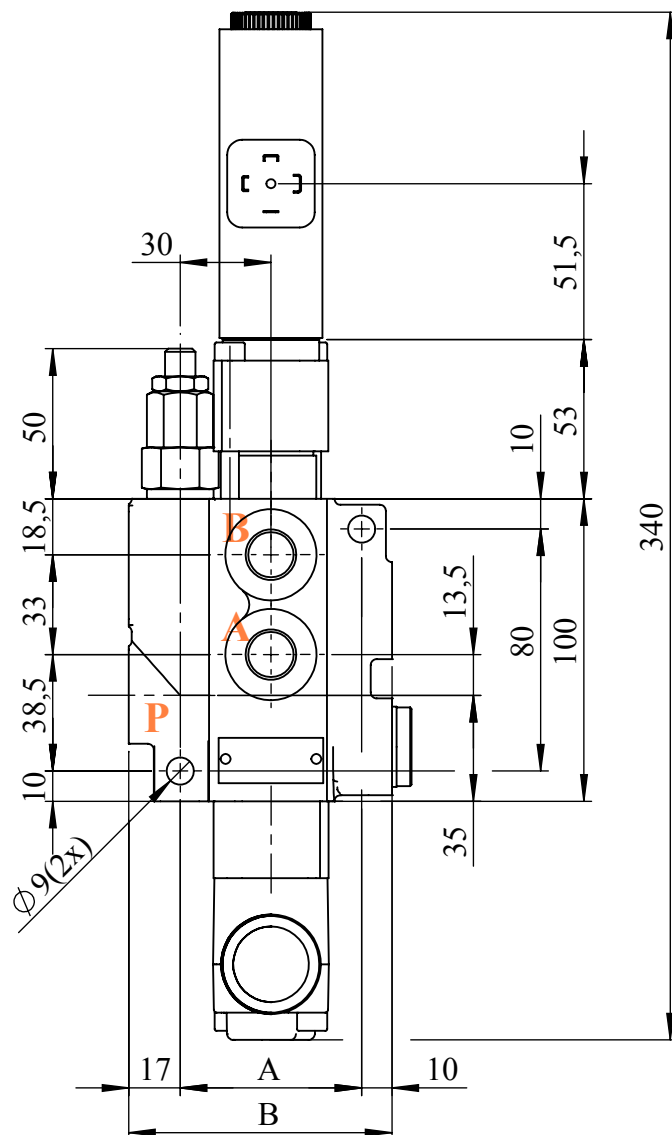
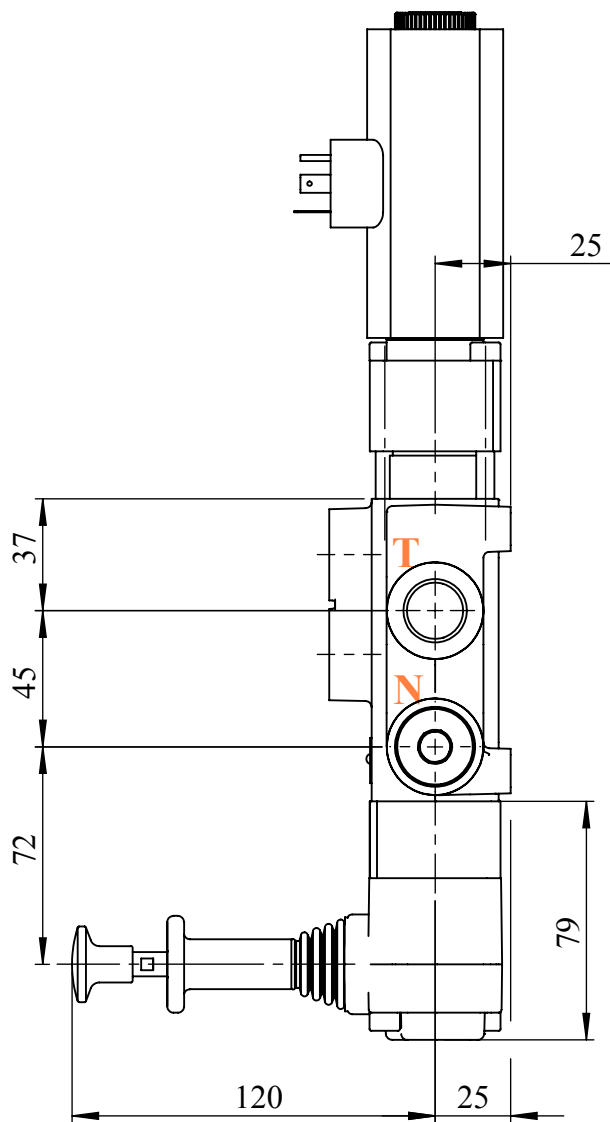

	A	B
Z50 A1ESD	60	85
02Z50 A1ESD	97	129
03Z50 A1ESD	132	164
04Z50 A1ESD	167	199
05Z50 A1ESD	202	234
06Z50 A1ESD	237	269
07Z50 A1ESD	272	304

*Spool to spool distance - 35 mm

Possible placement of a carry-over at N

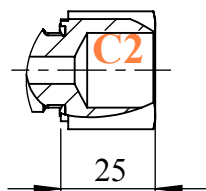

Hydraulic scheme of 1Z50A1ESD K1

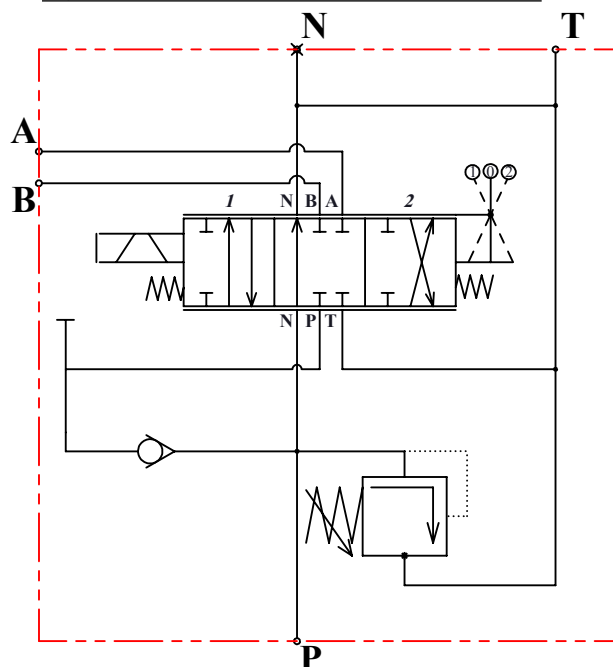

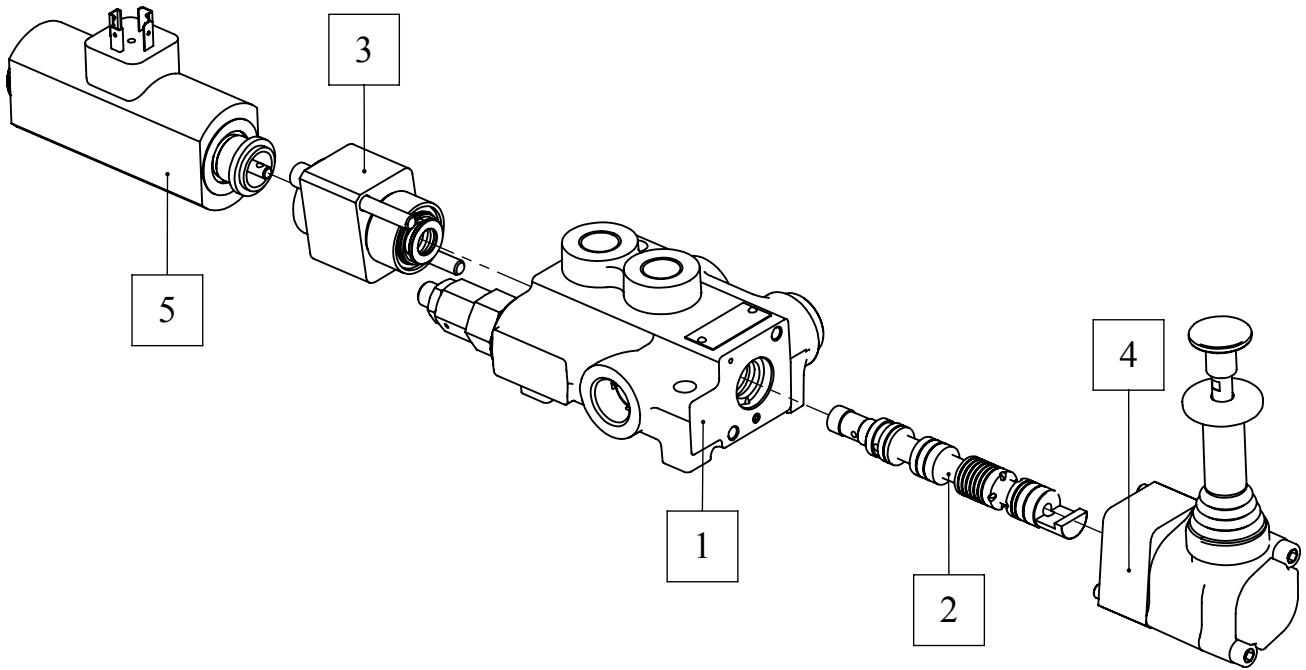

Description example:

Z50 / A / 1ESD K1 / G1/2-24VDC

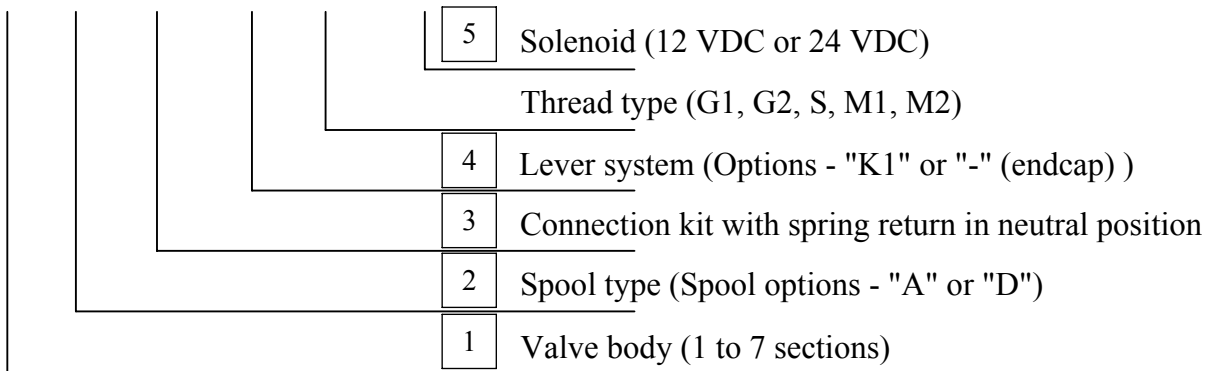

Availabe threads for that valve:

BSP (order code G1/2)

Working ports A, B: G 1/2
 Inlet port P: G 1/2
 Outlet port T: G 1/2
 Port N: G 1/2

METRIC (order code M)

Working ports A, B: M18x1.5
 Inlet port P: M22x1.5
 Outlet port T: M22x1.5
 Port N: M22x1.5

UN-UNF (order code S)

Working ports A, B: 3/4-16UNF
 Inlet port P: 7/8-14UNF
 Outlet port T: 7/8-14UNF
 Port N: 7/8-14UNF

BSP (order code G)

Working ports A, B: G 3/8
 Inlet port P: G 1/2
 Outlet port T: G 1/2
 Port N: G 1/2

Electric wiring example

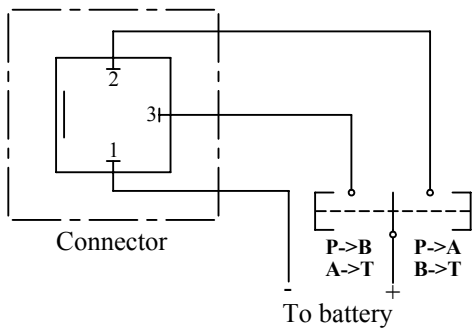

1ESD K1 kit

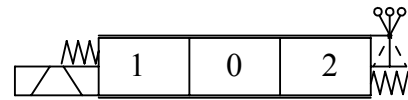

1ESD - (end cap)

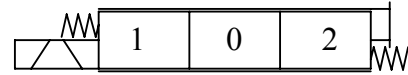

Operating features

CONTROL

Internal Leakage A(B)->T

($\Delta p=100 \text{ bar} - 1450 \text{ psi} / T = 40^\circ\text{C}$) : max 25 ccm/min - 1.1 cin/min

COIL

Nominal voltage tolerance.....: $\pm 10 \%$

Power rating.....: 53 W

Coil insulation.....: class H

Duty cycle.....: 100 %

Spool A

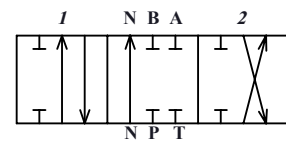

Spool D

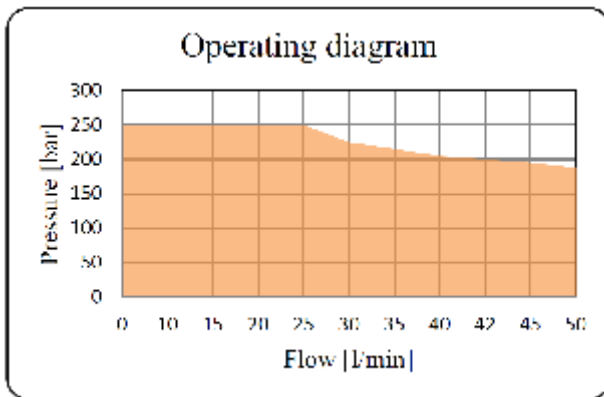
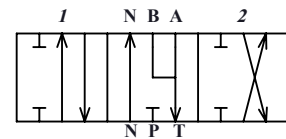

Manual operation:
lift the bush to lever
unlocking

