

HYDRAULIC MOTORS HW

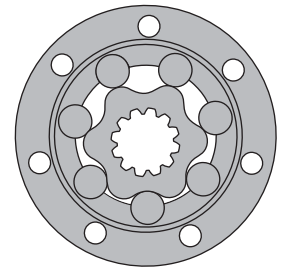

APPLICATION

- » Conveyors
- » Feeding mechanism of robots and manipulators
- » Metal working machines
- » Textile machines
- » Agricultural machines
- » Food industries
- » Grass cutting machinery etc.



CONTENTS

Specification data103÷104
 Function diagrams105÷111
 Dimensions and mounting112÷116
 Permissible shaft Seal Pressure ...116
 Shaft extensions117÷118
 Permissible shaft loads118
 Order code119

OPTIONS

- » Model - Spool valve, roll-gerotor
- » Wheel and flange mount
- » Shafts - straight, splined and tapered
- » BSPP and SAE ports
- » Other special features

GENERAL

Max. Displacement, cm ³ /rev [in ³ /rev]	550 [33.55]
Max. Speed, [RPM]	497
Max. Torque, daNm [in-lb]	cont.: 96 [8500] int.: 105 [9293]
Max. Output, kW [HP]	23,1 [31]
Max. Pressure Drop, bar [PSI]	cont.: 205 [3000] int.: 225 [3260]
Max. Oil Flow, lpm [GPM]	115 [30.4]
Min. Speed, [RPM]	10
Pressure fluid	Mineral based- HLP(DIN 51524) or HM(ISO 6743/4)
Temperature range, °C [°F]	-40÷140 [-40÷284]
Optimal Viscosity range, mm ² /s [SUS]	20÷75 [98÷347]
Filtration	ISO code 20/16 (Min. recommended fluid filtration of 25 microns)

Oil flow in drain line

Pressure drop bar [PSI]	Viscosity mm ² /s [SUS]	Oil flow in drain line lpm [GPM]
100 [1450]	20 [98]	2,5 [.660]
	35 [164]	1,8 [.476]
140 [2030]	20 [98]	3,5 [.925]
	35 [164]	2,8 [.740]

Pressure Losses

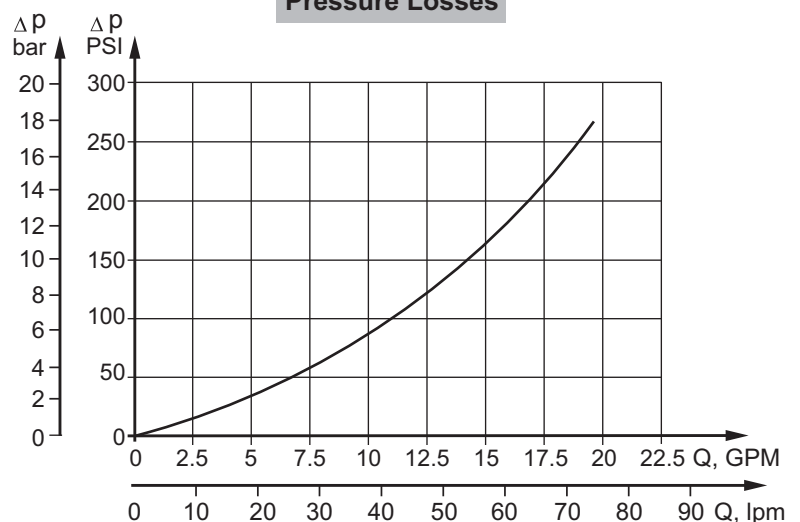

SPECIFICATION DATA

Type		HW 125	HW 160	HW 200	HW 235	HW 250	HW 300	HW 315
Displacement, cm³/rev [in³/rev]		126 [7.69]	157,8 [9.64]	201,3 [12.28]	235,3 [14.33]	252 [15.37]	300 [18.3]	314,9 [19.21]
Max. Speed, [RPM]	cont.	357	380	373	319	298	250	238
	int.*	476	475	497	425	397	333	318
Max. Torque daNm [in-lb]	cont.	35 [3098]	44 [3894]	55 [4868]	64,5 [5710]	69 [6107]	81 [7170]	85 [7523]
	int.*	38,5 [3408]	48 [4248]	60 [5310]	70 [6196]	75 [6638]	89 [7877]	93 [8230]
Max. Output, kW [HP]	cont.	16,2 [21.7]	17,6 [23.6]	18,6 [24.9]	18,2 [24.4]	16,8 [22.5]	16,5 [22]	16,4 [21.9]
	int.*	19,8 [26.6]	21,6 [29]	23,1 [31]	22,6 [30.3]	20,8 [27.9]	20,8 [27.9]	20,8 [27.9]
Max. Pressure Drop, bar [PSI]	cont.	205 [2970]	205 [2970]	205 [2970]	205 [2970]	205 [2970]	205 [2970]	205 [2970]
	int.*	225 [3260]	225 [3260]	225 [3260]	225 [3260]	225 [3260]	225 [3260]	225 [3260]
Max. Oil Flow lpm [GPM]	cont.	45 [12]	60 [16]	75 [20]	75 [20]	75 [20]	75 [20]	75 [20]
	int.*	60 [16]	75 [20]	100 [26.4]	100 [26.4]	100 [26.4]	100 [26.4]	100 [26.4]
Max. Inlet Pressure, bar [PSI]	cont.	210 [3050]	210 [3050]	210 [3050]	210 [3050]	210 [3050]	210 [3050]	210 [3050]
	int.*	250 [3625]	250 [3625]	250 [3625]	250 [3625]	250 [3625]	250 [3625]	250 [3625]
Max. Starting Pressure with Unloaded Shaft, bar [PSI]		10 [145]	10 [145]	10 [145]	10 [145]	10 [145]	10 [145]	10 [145]
Min. Starting Torque daNm [in-lb]	at max. press. drop cont.	28,7 [2540]	36 [3186]	45,1 [3991]	52,8 [4673]	56,5 [5000]	66,4 [5877]	69,7 [6169]
	at max. press. drop int.*	31,5 [2788]	39,3 [3478]	49,2 [4355]	57,4 [5080]	61,5 [5443]	72,9 [6452]	76,2 [6744]
Min. Speed**, [RPM]		10	10	10	10	10	10	10
Weight, avg. kg [lb]	HW	14,3 [31.5]	14,6 [32.2]	15,1 [33.3]	15,5 [34.2]	15,7 [34.6]	16,1 [35.5]	16,3 [35.9]
	HWF	12,8 [28.2]	13,1 [28.9]	13,6 [30.0]	14,0 [30.9]	14,2 [31.3]	14,6 [32.2]	14,8 [32.6]
	HWFR(FV)	14,8 [32.6]	15,1 [33.3]	15,6 [34.4]	16,0 [35.3]	16,2 [35.7]	16,6 [36.6]	16,8 [37.0]
	HWS	14,0 [30.9]	14,3 [31.5]	14,8 [32.6]	15,2 [33.5]	15,4 [34.0]	15,8 [34.8]	16,0 [35.3]
	HWSR	16,0 [35.3]	16,3 [35.9]	16,8 [37.0]	17,2 [37.9]	17,4 [38.4]	17,8 [39.2]	18,0 [39.7]
	HWD	14,5 [31.9]	14,8 [32.6]	15,3 [33.7]	15,7 [34.6]	15,9 [35.1]	16,3 [35.9]	16,5 [36.4]
	HWV	14,0 [30.86]	14,3 [31.5]	14,8 [32.6]	15,2 [33.5]	15,4 [33.9]	15,8 [34.8]	16,0 [35.2]
	HWE	14,7 [32.4]	15,0 [33.1]	15,5 [34.2]	15,9 [35.1]	16,1 [35.5]	16,5 [36.4]	16,7 [36.8]
	HWSE	14,4 [31.8]	14,7 [32.4]	15,2 [33.5]	15,6 [34.4]	15,8 [34.8]	16,2 [35.7]	16,4 [36.2]
	HWFE	13,2 [29.1]	13,5 [29.8]	14,0 [30.86]	14,4 [31.8]	14,6 [32.2]	15,0 [33.1]	15,2 [33.5]

* Intermittent operation: the permissible values may occur for max. 10% of every minute.

** For speeds lower than given, consult factory or your regional manager.

*** For "E"-option it is not recommendable a flow bigger than 75% of the nominal flow rate.

- Intermittent speed and intermittent pressure drop must not occur simultaneously.
- Recommended filtration is per ISO cleanliness code 20/16. A nominal filtration of 25 micron or better.
- Recommend using a premium quality, anti-wear type mineral based hydraulic oil HLP(DIN51524) or HM (ISO 6743/4).
If using synthetic fluids consult the factory for alternative seal materials.
- Recommended minimum oil viscosity 13 mm²/s [70 SUS] at 50°C [122°F].
- Recommended maximum system operating temperature is 82°C [180°F].
- To assure optimum motor life fill with fluid prior to loading and run at moderate load and speed for 10-15 minutes.

SPECIFICATION DATA

Type		HW 350	HW 370	HW 400	HW 470	HW 500	HW 535	HW 550
Displacement, cm³/rev [in³/rev]		347,8 [21.21]	369,2 [22.51]	396,8 [24.2]	470,6 [28.71]	502,4 [30.65]	535 [32.7]	550 [33.55]
Max. Speed, [RPM]	cont.	216	203	189	159	149	140	136
	int.*	288	271	252	244	229	215	209
Max. Torque daNm [in-lb]	cont.	94 [8320]	96 [8497]	96 [8497]	92 [8143]	91 [8054]	90 [7966]	89 [7877]
	int.*	102 [9028]	105 [9293]	98 [8674]	101 [8939]	101 [8939]	104 [9205]	105 [9293]
Max. Output, kW [HP]	cont.	16,5 [22]	13,2 [17.7]	12,5 [16.8]	10,6 [14.2]	10,8 [14.5]	9,4 [12.6]	9 [12]
	int.*	20,8 [27.9]	19,2 [25.7]	18,5 [24.8]	17,4 [23.3]	17,8 [23.9]	16,4 [22]	15,8 [21.2]
Max. Pressure Drop, bar [PSI]	cont.	205 [2970]	200 [2900]	185 [2680]	150 [2180]	140 [2030]	130 [1885]	125 [1815]
	int.*	225 [3260]	220 [3200]	190 [2760]	165 [2390]	155 [2250]	150 [2180]	145 [2105]
Max. Oil Flow lpm [GPM]	cont.	75 [20]	75 [20]	75 [20]	75 [20]	75 [20]	75 [20]	75 [20]
	int.*	100 [26.4]	100 [26.4]	100 [26.4]	115 [30.4]	115 [30.4]	115 [30.4]	115 [30.4]
Max. Inlet Pressure, bar [PSI]	cont.	210 [3050]	210 [3050]	210 [3050]	210 [3050]	210 [3050]	210 [3050]	210 [3050]
	int.*	250 [3625]	250 [3625]	250 [3625]	250 [3625]	250 [3625]	250 [3625]	250 [3625]
Max. Starting Pressure with Unloaded Shaft, bar [PSI]		10 [145]	10 [145]	10 [145]	10 [145]	10 [145]	10 [145]	10 [145]
Min. Starting Torque daNm [in-lb]	at max. press. drop cont.	77 [6815]	79,5 [7036]	78,7 [6966]	75,4 [6674]	74,6 [6603]	73,8 [6532]	72,9 [6452]
	at max. press. drop int.*	83,6 [7400]	86 [7612]	80,3 [7107]	82,8 [7328]	82,8 [7328]	85,2 [7540]	84,4 [7470]
Min. Speed**, [RPM]		8	8	8	8	8	5	5
Weight, avg. kg [lb]	HW	16,7 [36.8]	16,9 [37.3]	17,3 [38.1]	18,1 [39.9]	18,4 [40.6]	18,8 [41.5]	18,9 [41.7]
	HWF	15,2 [33.5]	15,4 [34.0]	15,8 [34.8]	16,6 [36.6]	16,9 [37.3]	17,3 [38.1]	17,4 [38.3]
	HWFR(FV)	17,2 [37.9]	17,4 [38.4]	17,8 [39.2]	18,6 [41.0]	18,9 [41.7]	19,3 [42.5]	19,4 [42.8]
	HWS	16,4 [36.2]	16,6 [36.6]	17,0 [37.5]	17,8 [39.2]	18,1 [39.9]	18,5 [40.8]	18,6 [41.0]
	HWSR	18,4 [40.6]	18,6 [41.0]	19,0 [41.9]	19,8 [43.7]	20,1 [44.3]	20,5 [45.2]	20,6 [45.4]
	HWD	16,8 [37.0]	17,1 [37.7]	17,5 [38.6]	18,3 [40.3]	18,6 [41.0]	19,0 [41.9]	19,1 [42.1]
	HWV	16,4 [36.2]	16,6 [36.6]	17,0 [37.5]	17,8 [39.7]	18,1 [39.9]	18,5 [40.8]	18,6 [41.0]
	HWE	17,1 [37.7]	17,3 [38.1]	17,7 [39.0]	18,5 [40.8]	18,9 [41.7]	19,2 [42.3]	19,3 [42.5]
	HWSE	16,8 [37.0]	17,0 [37.5]	17,4 [38.4]	18,2 [40.1]	18,5 [40.8]	18,9 [41.7]	19,0 [41.9]
HWFE	15,6 [34.4]	15,8 [34.8]	16,2 [35.7]	17,0 [37.5]	17,3 [38.1]	17,7 [39.0]	17,8 [39.7]	

* Intermittent operation: the permissible values may occur for max. 10% of every minute.

** For speeds lower than given, consult factory or your regional manager.

*** For "E"-option it is not recommendable a flow bigger than 75% of the nominal flow rate.

1. Intermittent speed and intermittent pressure drop must not occur simultaneously.
2. Recommended filtration is per ISO cleanliness code 20/16. A nominal filtration of 25 micron or better.
3. Recommend using a premium quality, anti-wear type mineral based hydraulic oil HLP(DIN51524) or HM (ISO 6743/4).
If using synthetic fluids consult the factory for alternative seal materials.
4. Recommended minimum oil viscosity 13 mm²/s [70 SUS] at 50°C [122°F].
5. Recommended maximum system operating temperature is 82°C [180°F].
6. To assure optimum motor life fill with fluid prior to loading and run at moderate load and speed for 10-15 minutes.

FUNCTION DIAGRAMS

HW 125

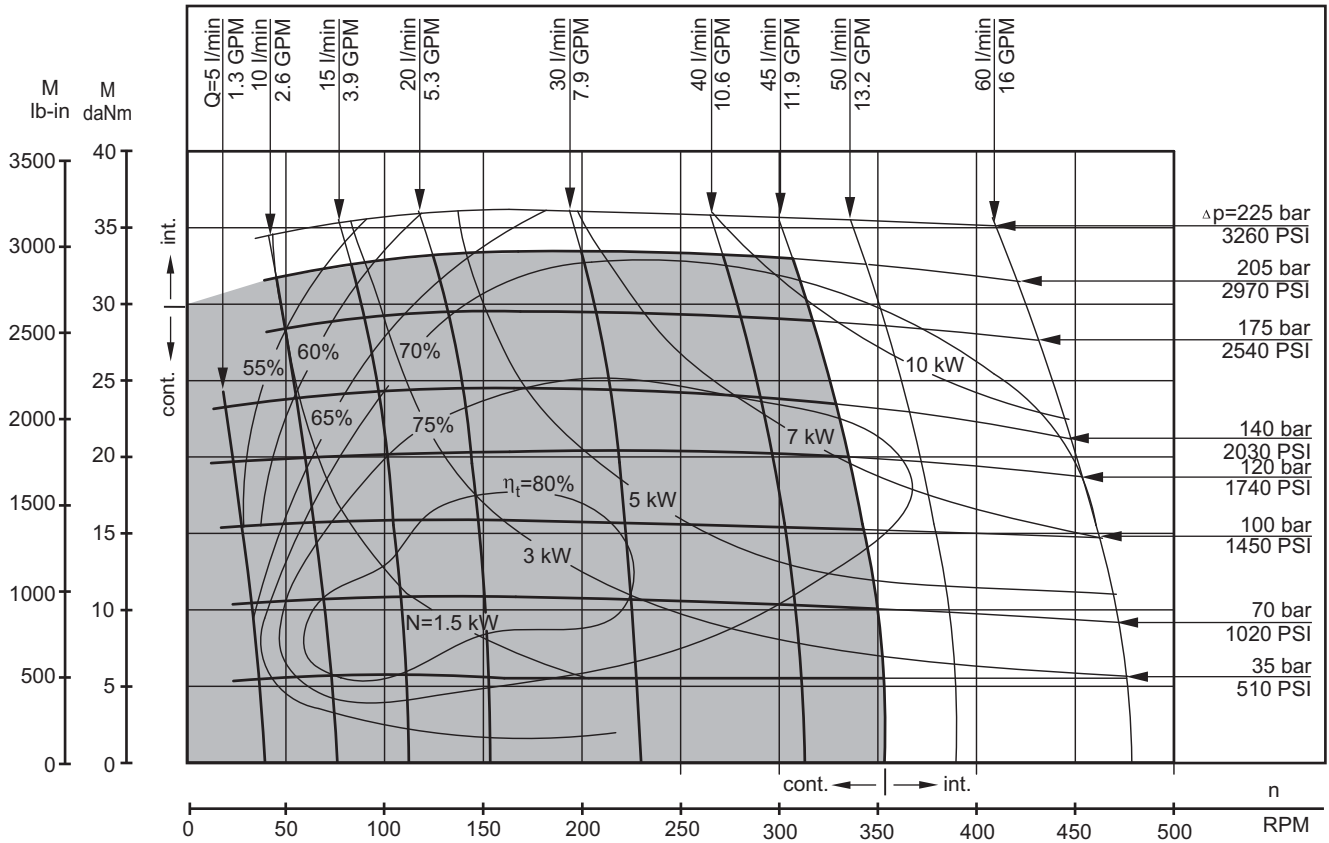

HW 160

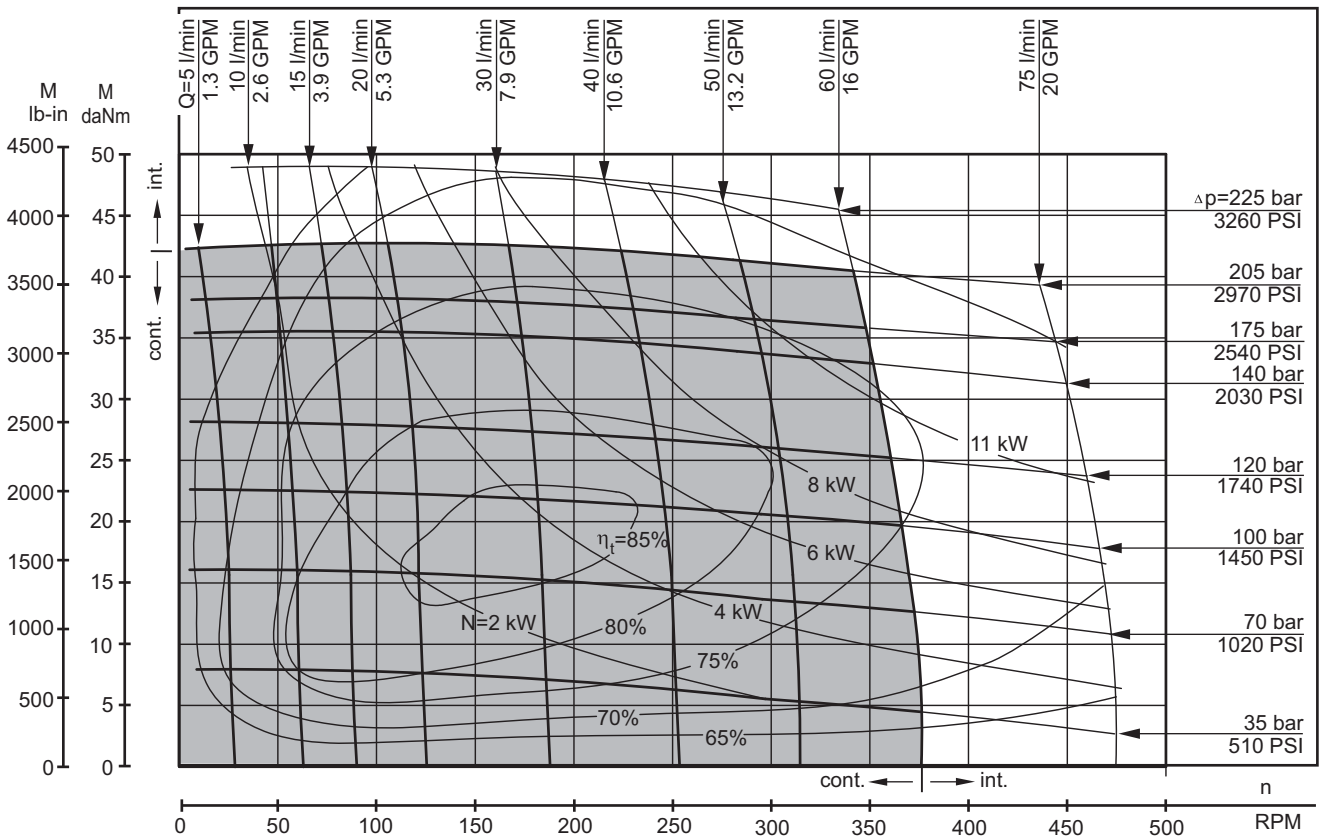

The function diagrams data is for average performance of randomly selected motors at back pressure 5 ± 10 bar [72.5 \pm 145 PSI] and oil with viscosity of $32 \text{ mm}^2/\text{s}$ [150 SUS] at 50°C [122 $^\circ\text{F}$].

FUNCTION DIAGRAMS

HW 200

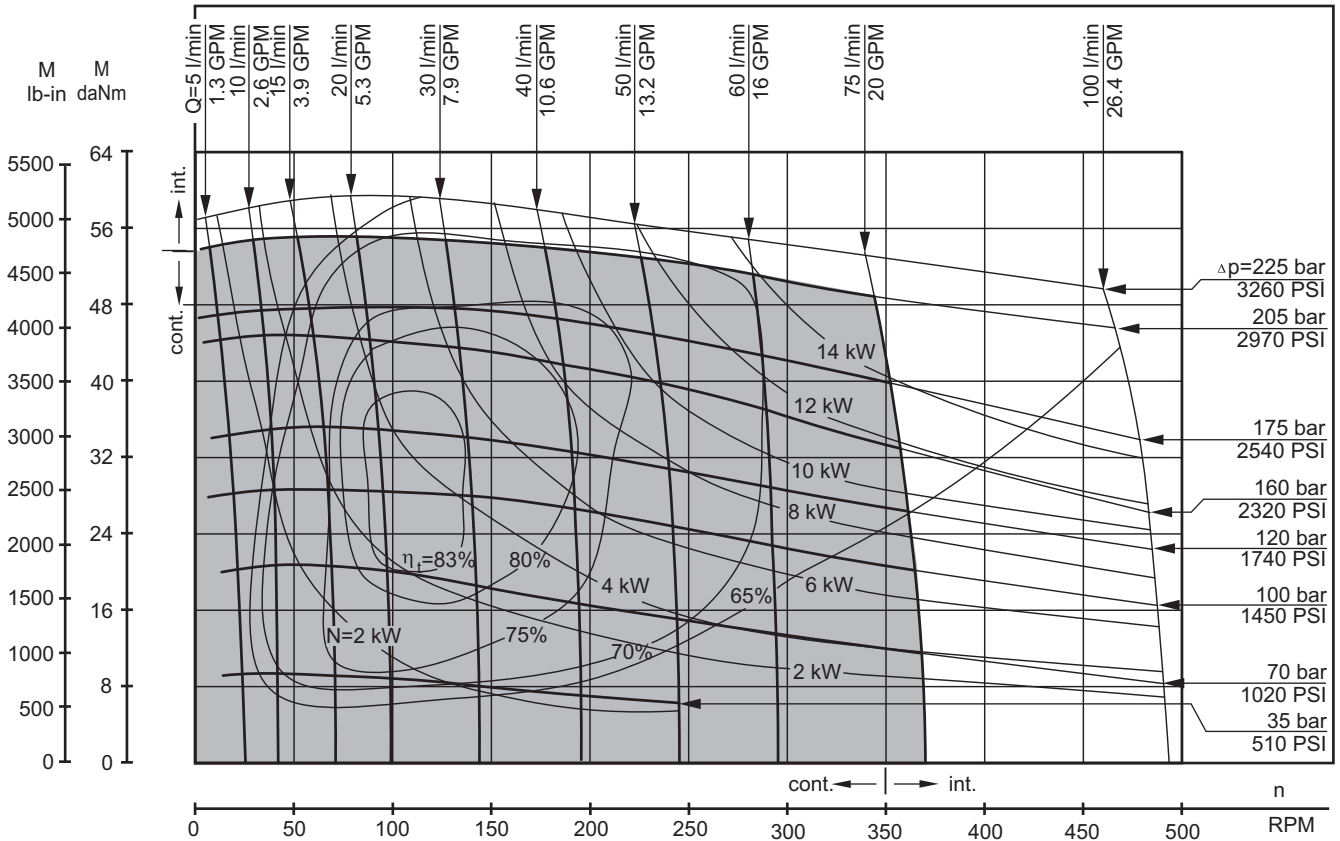

HW 235

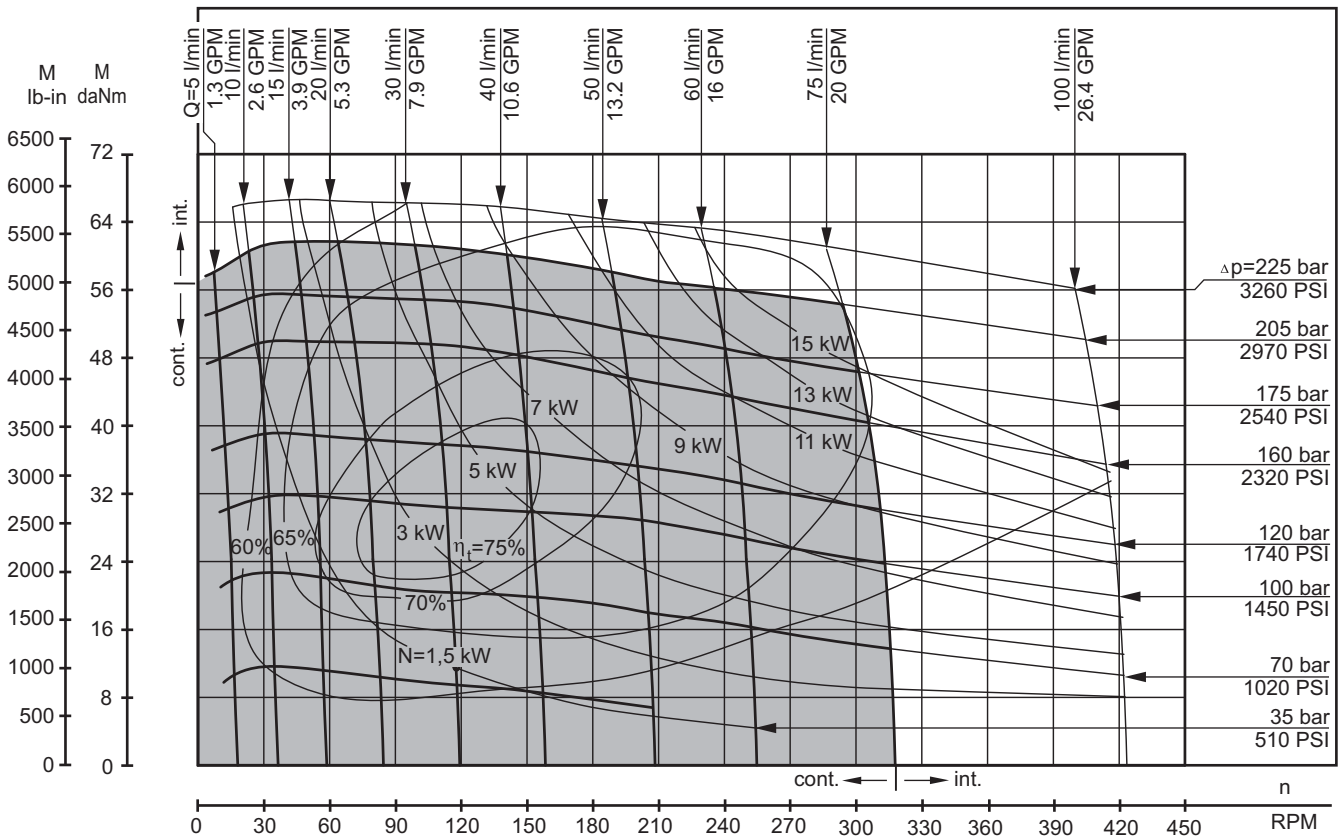

The function diagrams data is for average performance of randomly selected motors at back pressure 5 ± 10 bar [72.5 \pm 145 PSI] and oil with viscosity of 32 mm²/s [150 SUS] at 50°C [122°F].

FUNCTION DIAGRAMS

HW 250

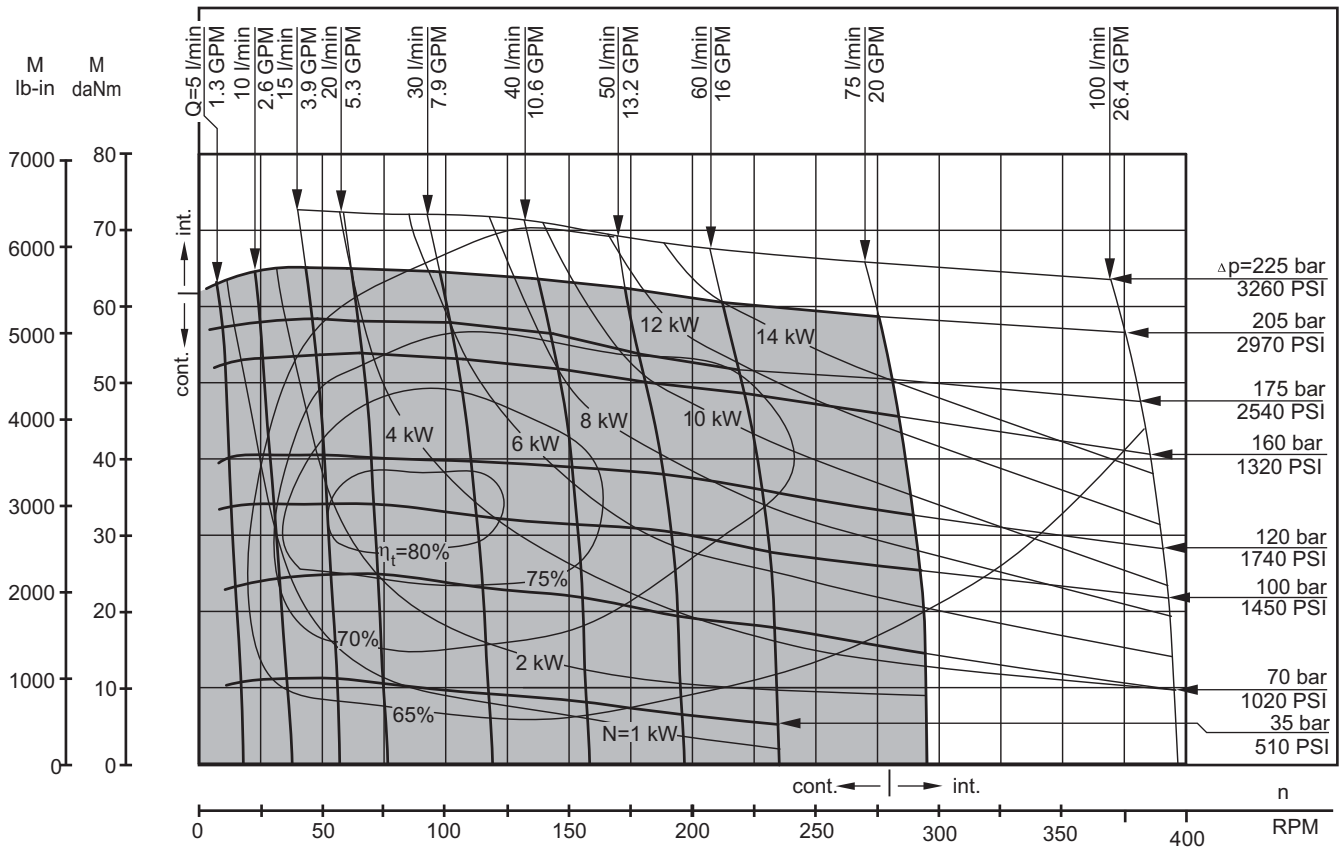

HW 300

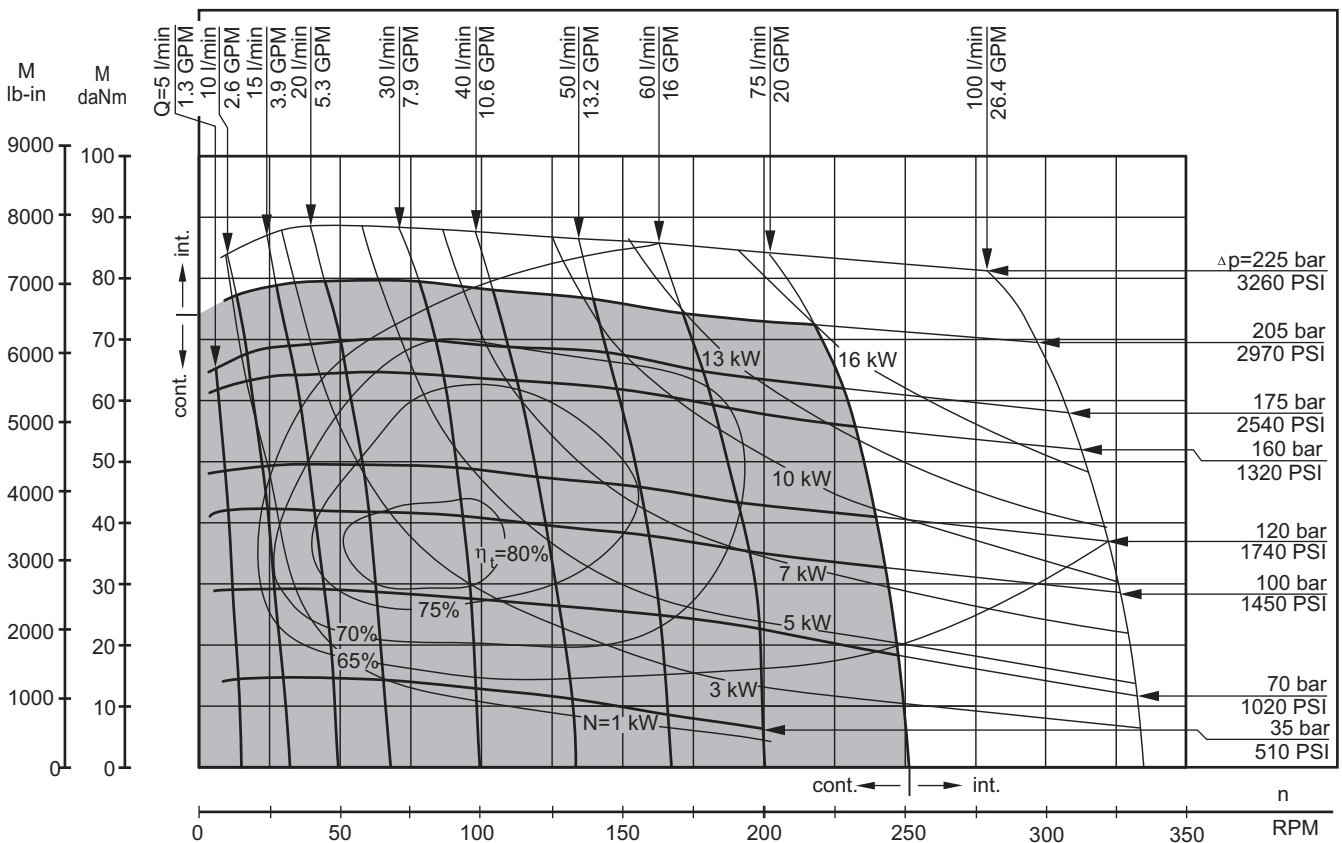

The function diagrams data is for average performance of randomly selected motors at back pressure 5 ± 10 bar [72.5 \pm 145 PSI] and oil with viscosity of 32 mm²/s [150 SUS] at 50°C [122°F].

FUNCTION DIAGRAMS

HW 315

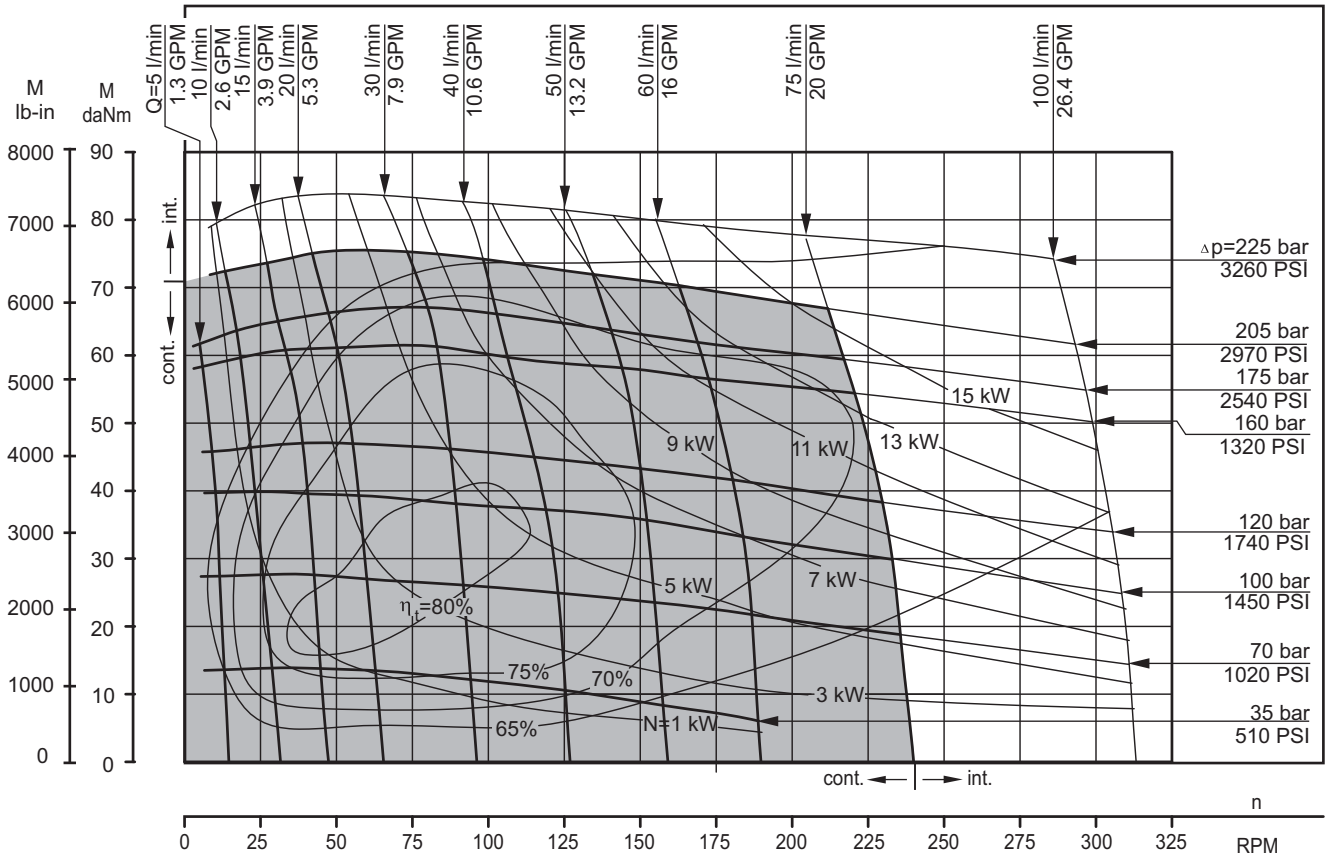

HW 350

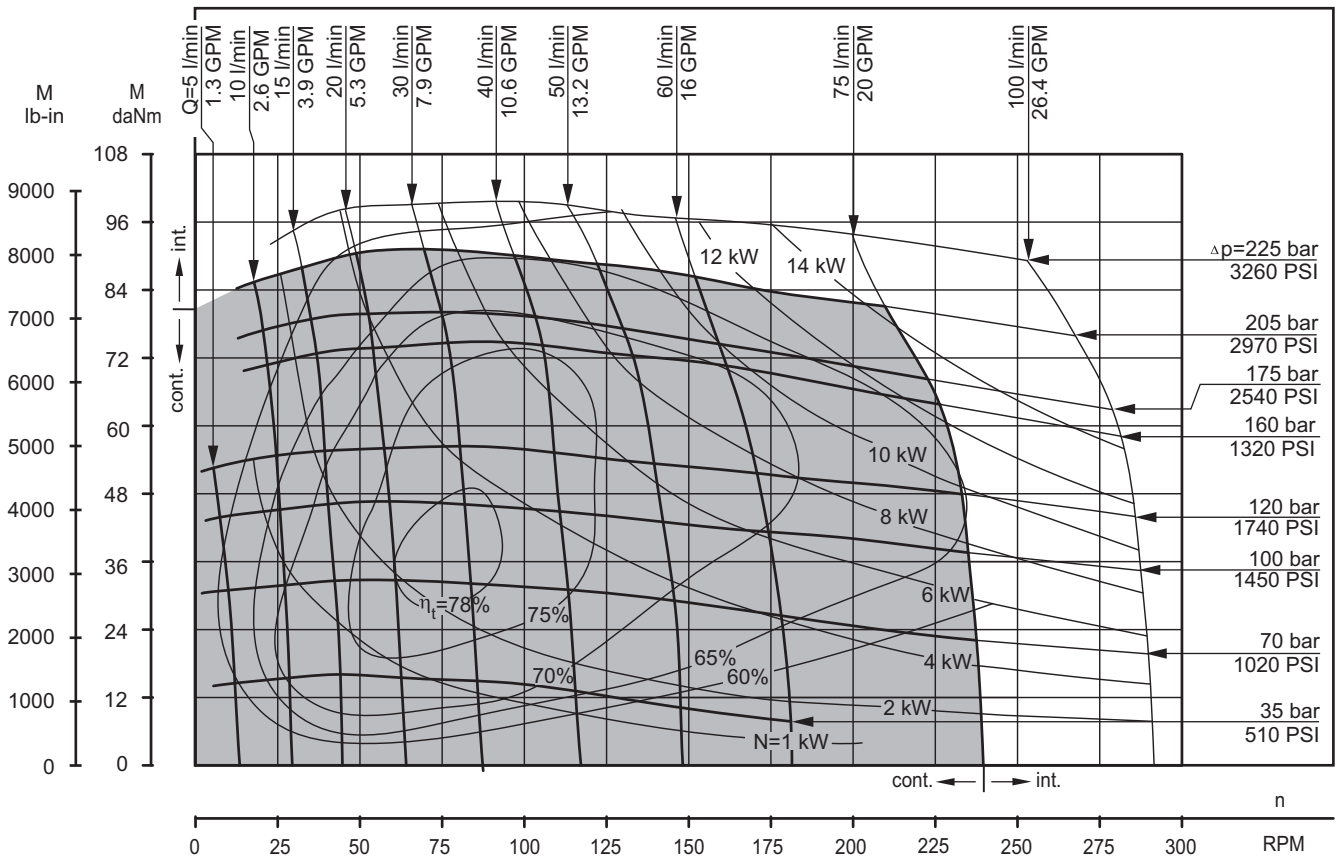

The function diagrams data is for average performance of randomly selected motors at back pressure 5±10 bar [72.5±145 PSI] and oil with viscosity of 32 mm²/s [150 SUS] at 50°C [122°F].

FUNCTION DIAGRAMS

HW 370

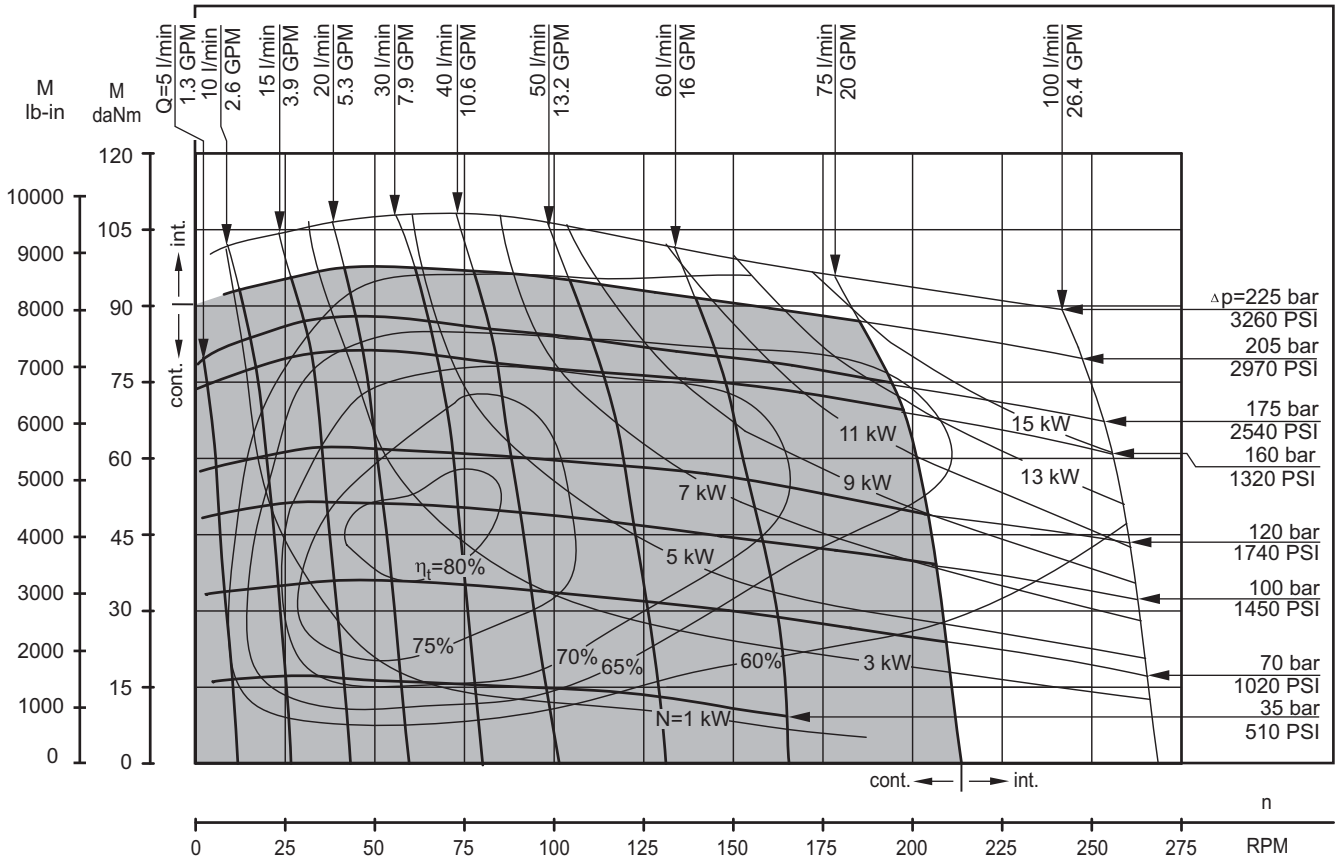

HW 400

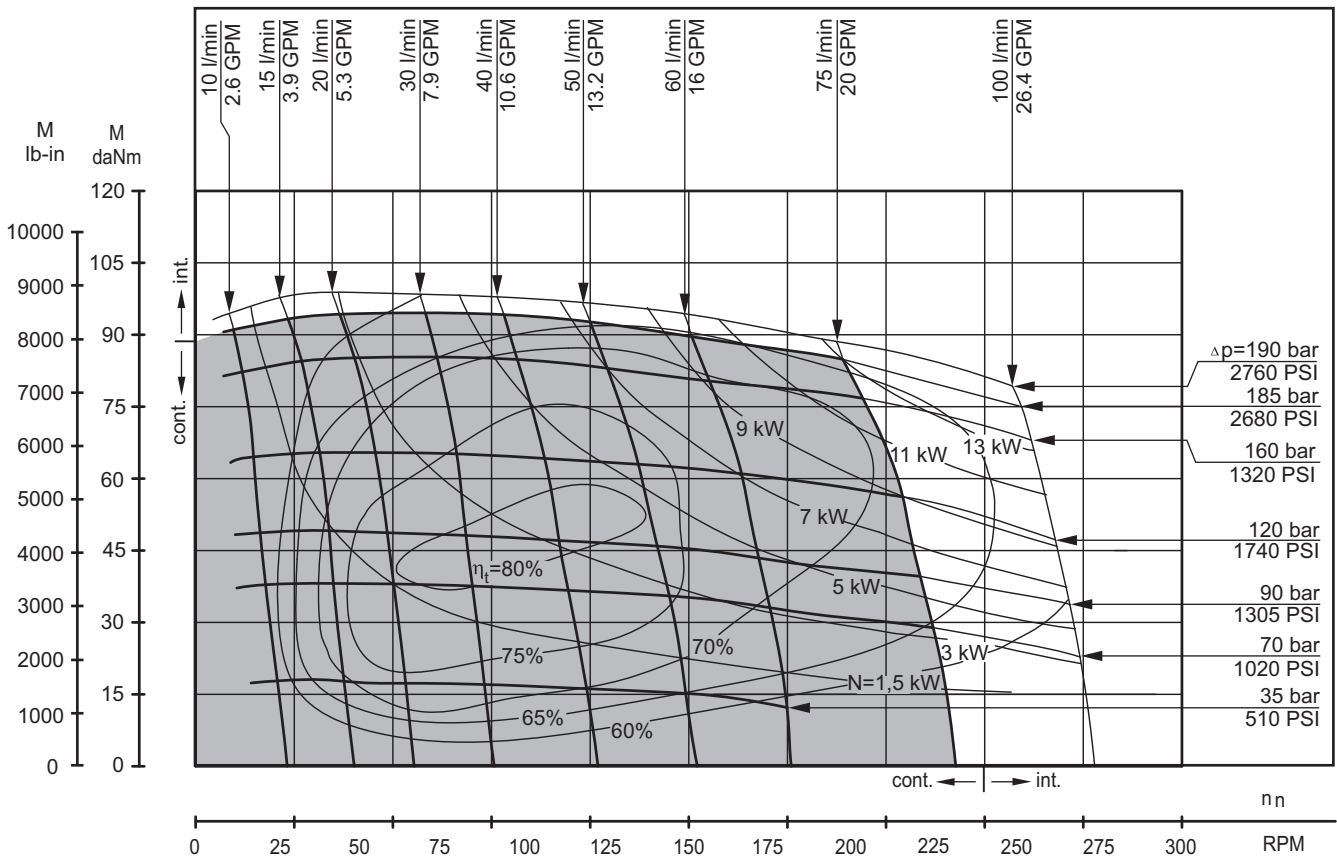

The function diagrams data is for average performance of randomly selected motors at back pressure 5±10 bar [72.5±145 PSI] and oil with viscosity of 32 mm²/s [150 SUS] at 50°C [122°F].

FUNCTION DIAGRAMS

HW 470

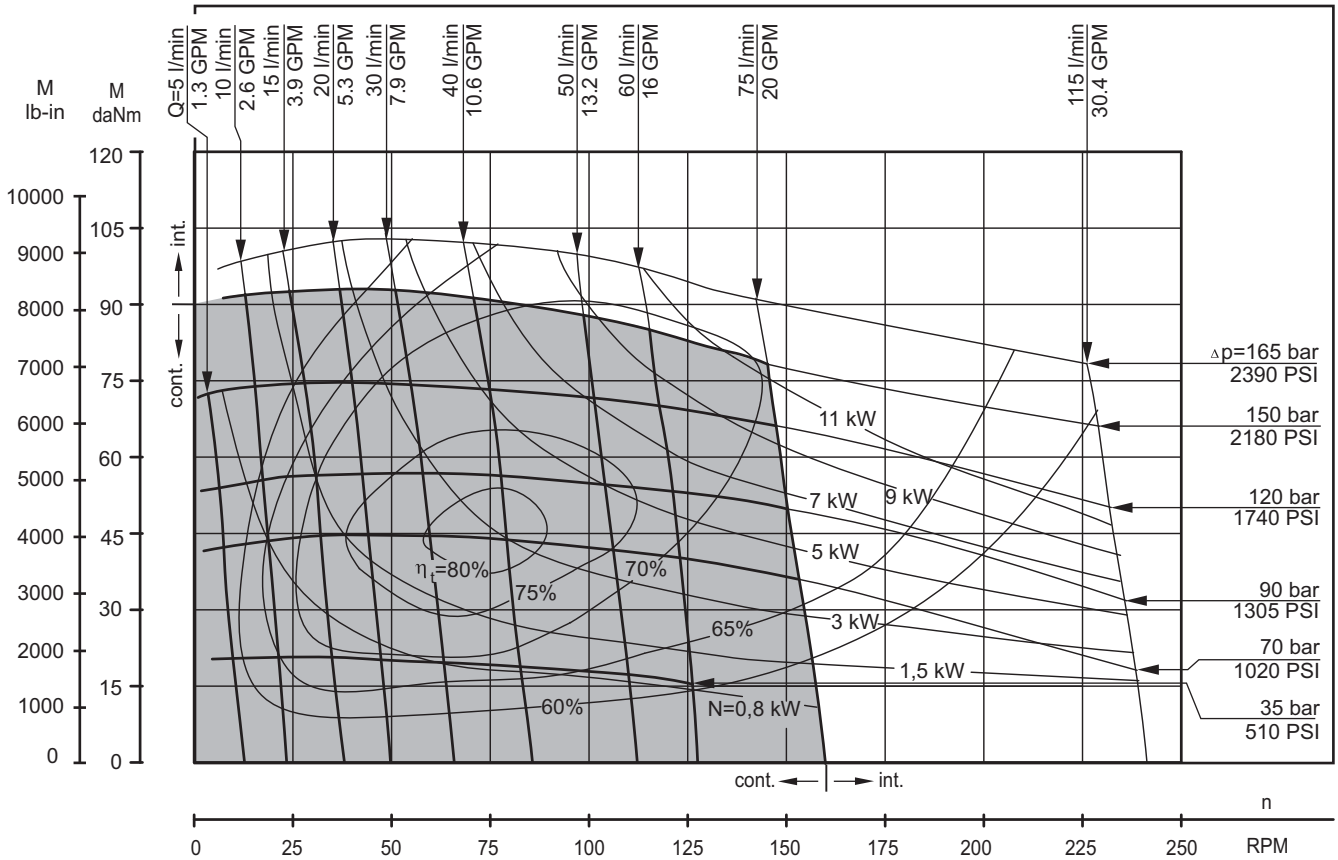

HW 500

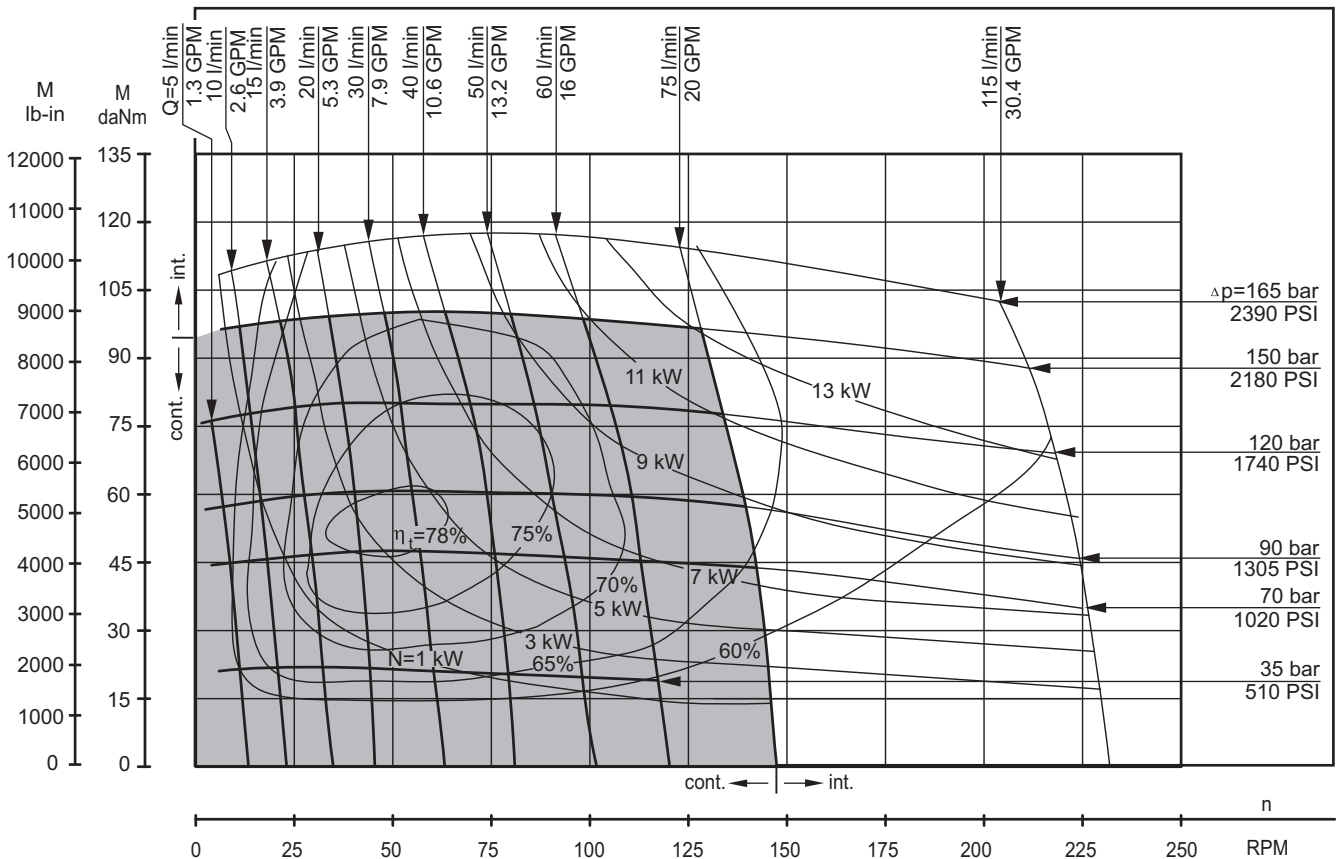

The function diagrams data is for average performance of randomly selected motors at back pressure 5 ± 10 bar [72.5 \pm 145 PSI] and oil with viscosity of 32 mm²/s [150 SUS] at 50°C [122°F].

FUNCTION DIAGRAMS

HW 535

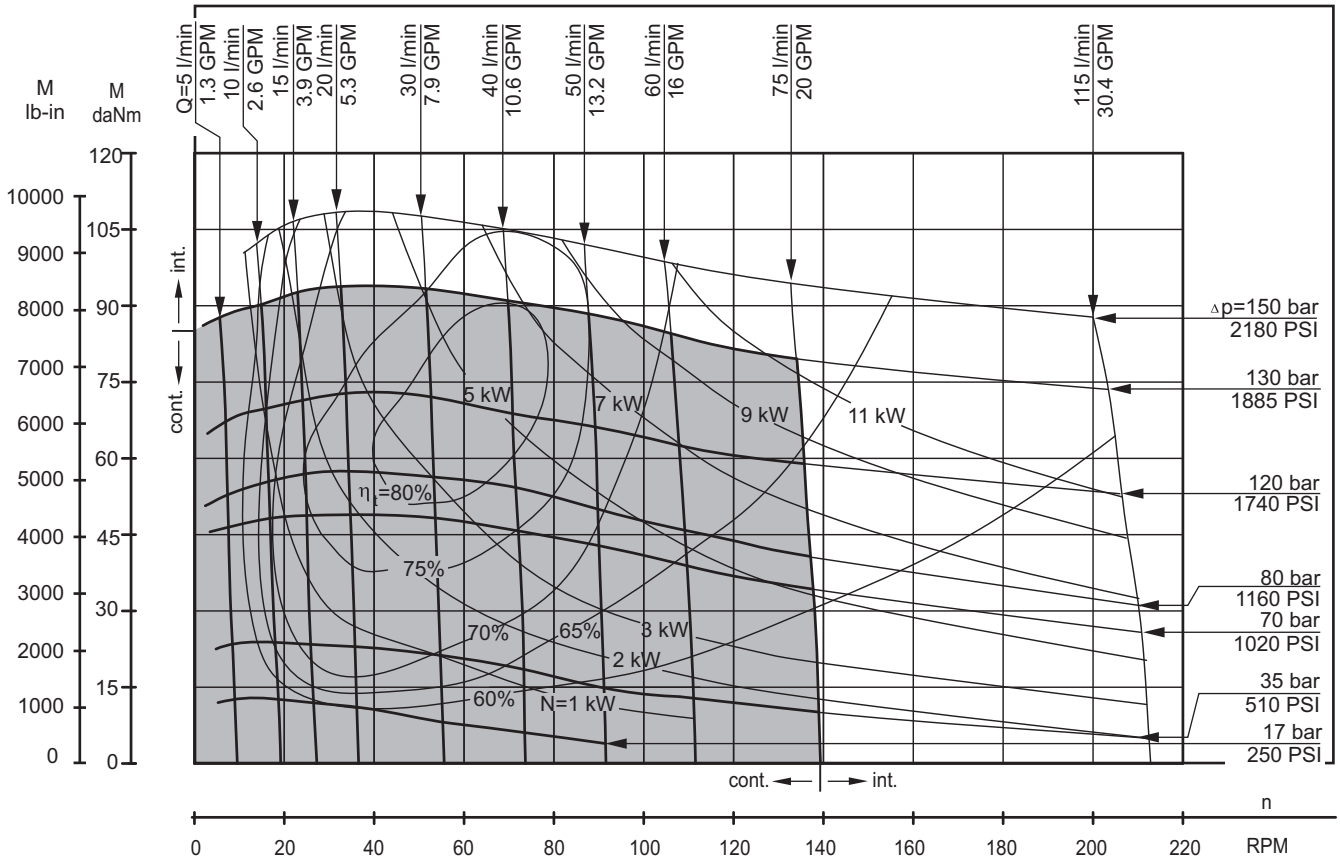

HW 550

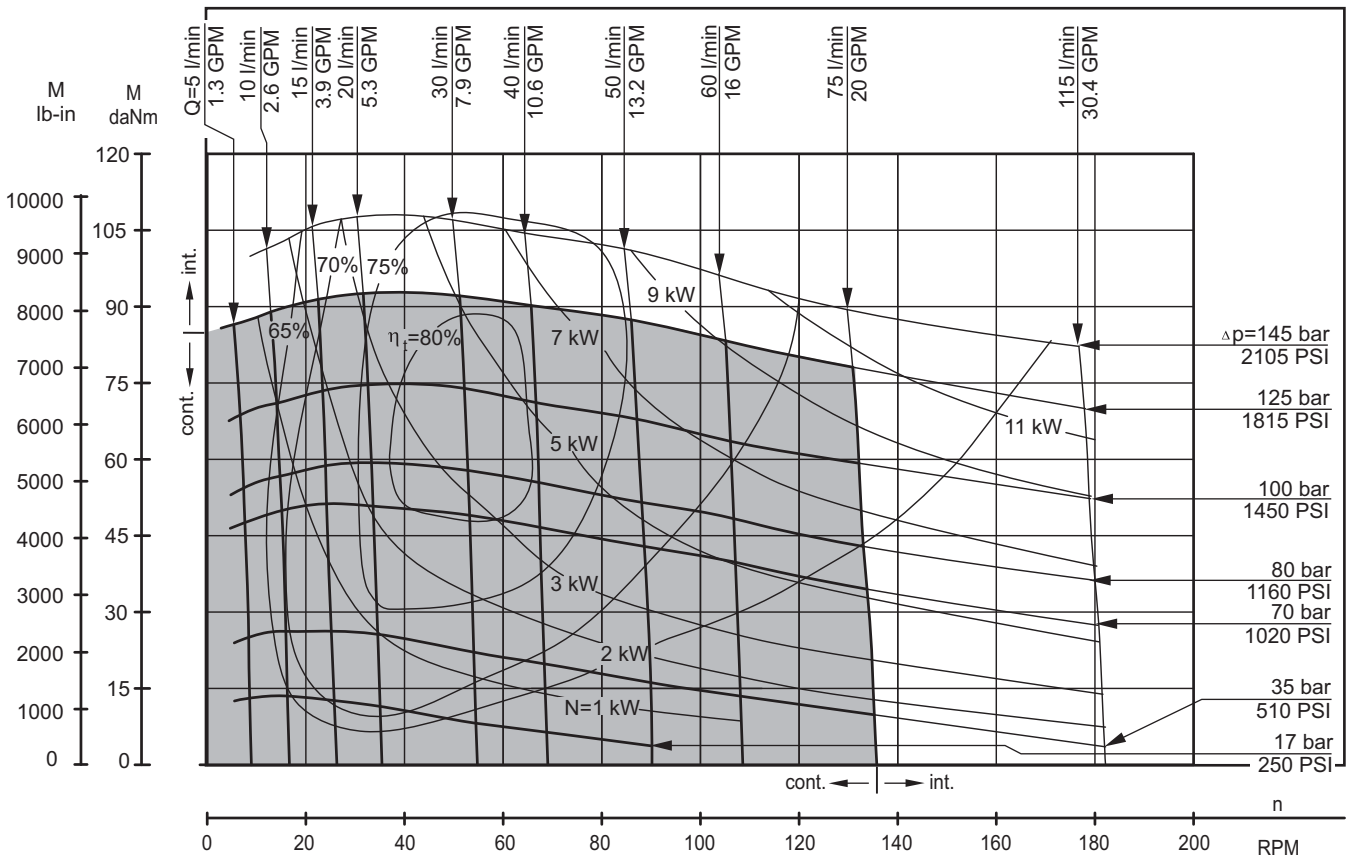

The function diagrams data is for average performance of randomly selected motors at back pressure 5±10 bar [72.5±145 PSI] and oil with viscosity of 32 mm²/s [150 SUS] at 50°C [122°F].

DIMENSIONS AND MOUNTING DATA

HW - Wheel Mount

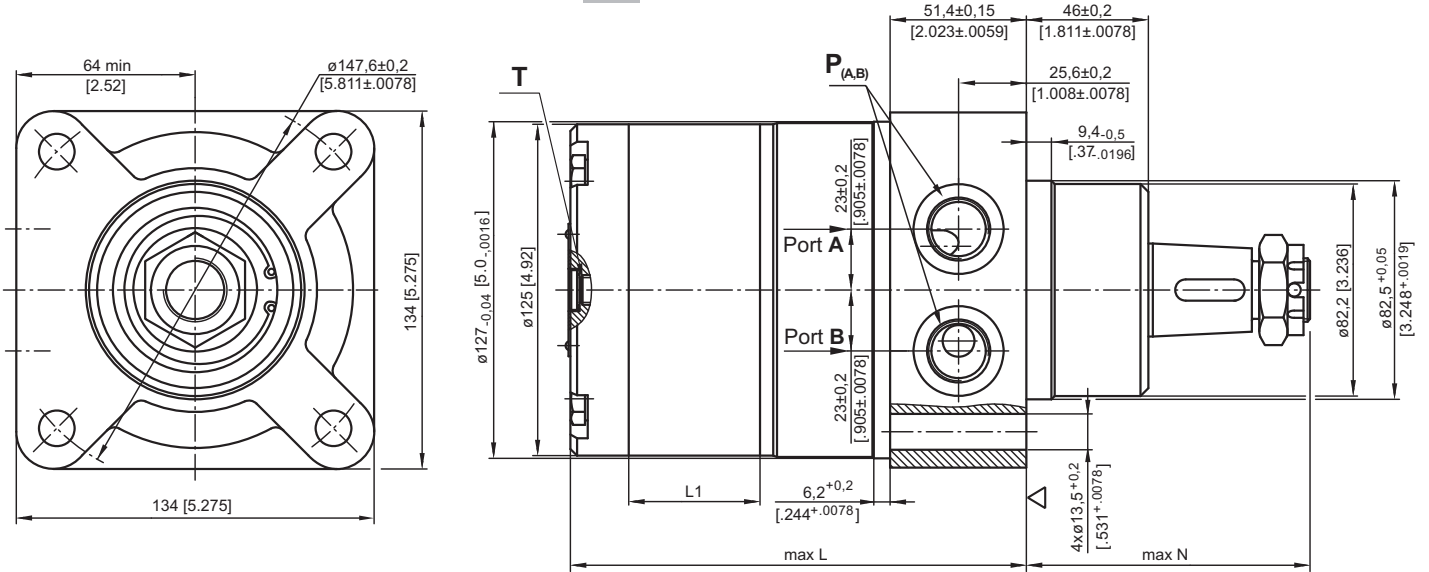

HWS - Wheel Mount

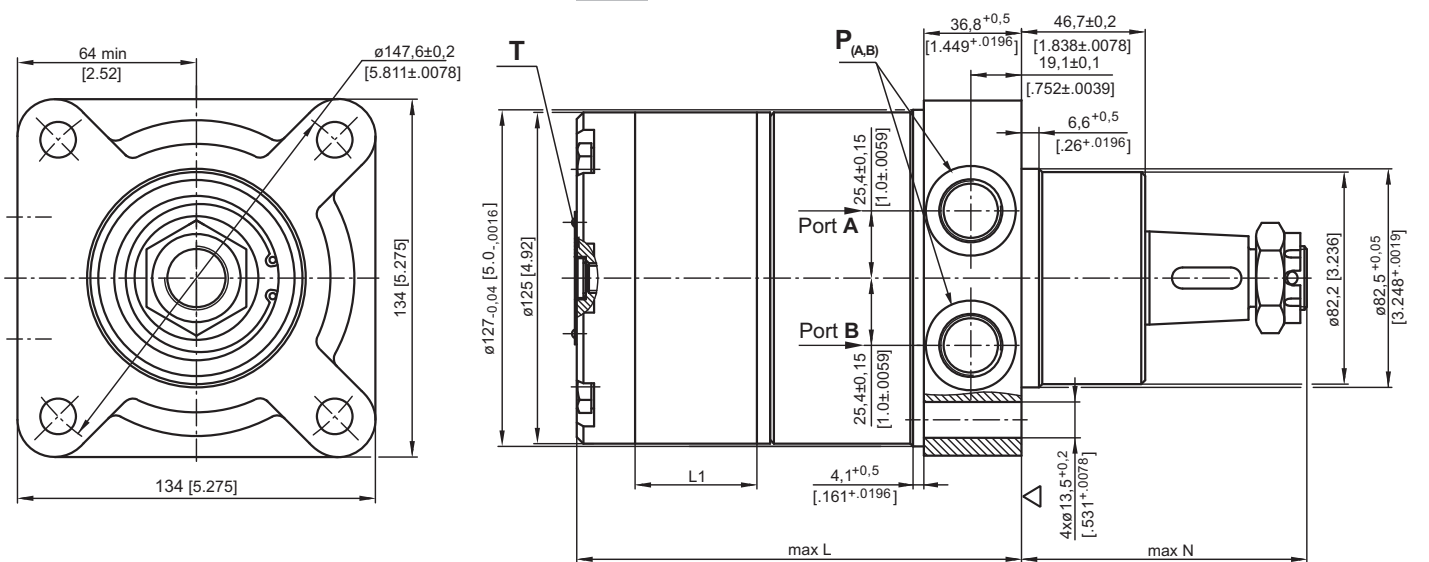

Type	*L, mm [in]	L ₁ , mm [in]
HW 125	140,5 [5.51]	17,4 [.68]
HW 160	145,0 [5.71]	21,8 [.86]
HW 200	151,0 [5.95]	27,8 [1.09]
HW 235	155,5 [6.12]	32,5 [1.28]
HW 250	158,0 [6.22]	34,8 [1.37]
HW 300	164,5 [6.48]	41,4 [1.63]
HW 315	166,5 [6.56]	43,5 [1.71]
HW 350	171,0 [6.73]	48,0 [1.89]
HW 370	174,0 [6.85]	51,0 [2.01]
HW 400	178,0 [7.01]	54,8 [2.16]
HW 470	188,0 [7.40]	65,0 [2.56]
HW 500	192,5 [7.58]	69,4 [2.73]
HW 535	197,0 [7.76]	74,1 [2.92]
HW 550	199,0 [7.84]	76,0 [2.99]

▽ - Motor Mounting Surface

	Versions	
	2	4
P _(A,B)	2xG $\frac{1}{2}$	2x $\frac{7}{8}$ -14UNF, O-ring
T	G $\frac{1}{4}$	$\frac{7}{16}$ -20UNF, O-ring

Note: For N see pages **117** and **118**.

Standard Rotation
Viewed from Shaft End
Port A Pressurized - **CW**
Port B Pressurized - **CCW**

Reverse Rotation
Viewed from Shaft End
Port A Pressurized - **CCW**
Port B Pressurized - **CW**



* For LSV option the dimension L is 3 mm [.118 in] greater.

DIMENSIONS AND MOUNTING DATA

HWSE - Wheel Mount, rear ports

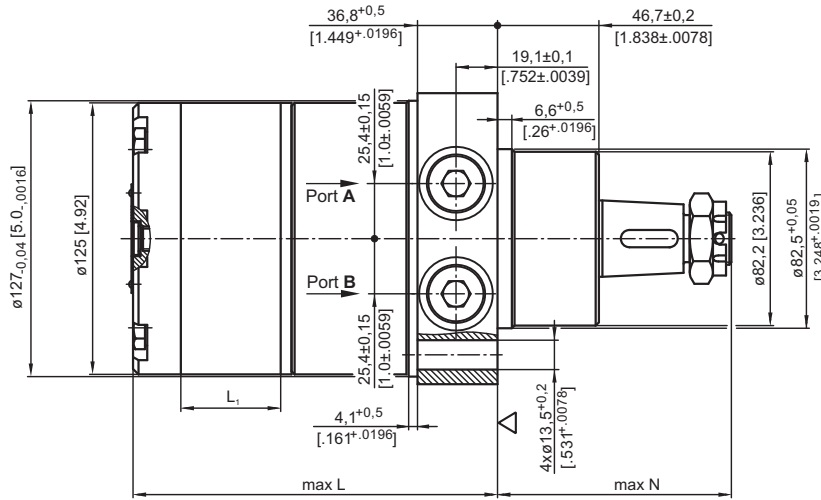

HWFE - Magneto Mount

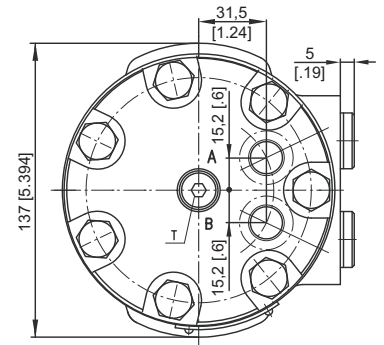

HWE - Wheel Mount, rear ports

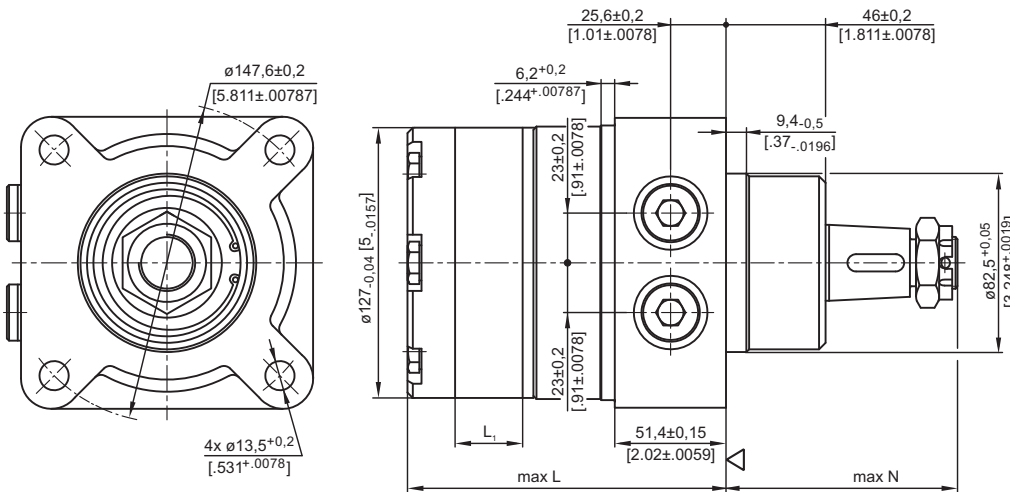

HW(S)E

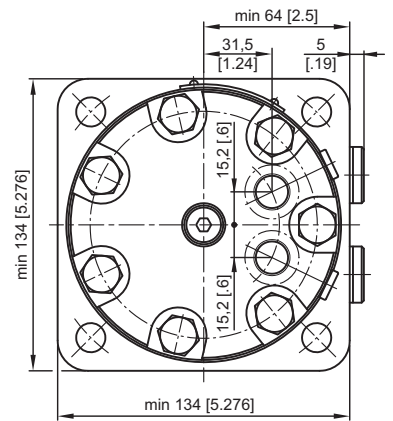

Type	*L, mm [in]		L ₁ , mm [in]
	HWE, HWSE	HWFE	
HW... 125	145,5 [5.73]	189,0 [7.44]	17,4 [0.68]
HW... 160	150,0 [5.91]	193,5 [7.62]	21,8 [0.86]
HW... 200	156,0 [6.14]	199,5 [7.85]	27,8 [1.09]
HW... 235	160,5 [6.32]	204,0 [8.03]	32,5 [1.28]
HW... 250	163,0 [6.42]	206,5 [8.13]	34,8 [1.37]
HW... 300	169,5 [6.67]	213,0 [8.39]	41,4 [1.63]
HW... 315	171,5 [6.75]	215,0 [8.46]	43,5 [1.71]
HW... 350	176,0 [6.93]	219,5 [8.64]	48,0 [1.89]
HW... 370	179,0 [7.05]	222,5 [8.76]	51,0 [2.01]
HW... 400	183,0 [7.20]	226,5 [8.92]	54,8 [2.16]
HW... 470	193,0 [7.60]	236,5 [9.31]	65,0 [2.56]
HW... 500	197,5 [7.78]	241,0 [9.49]	69,4 [2.73]
HW... 535	202,0 [7.95]	245,5 [9.67]	74,1 [2.92]
HW... 550	204,0 [8.03]	247,5 [9.74]	76,0 [2.99]

▽ - Motor Mounting Surface

	Versions	
	5	6
P _(A,B)	2xG 3/8	2x 9/16-18 UNF, O-ring
T	G 1/4	7/16-20 UNF, O-ring

Note: For N see pages 117 and 118.

Standard Rotation
Viewed from Shaft End
Port A Pressurized - **CW**
Port B Pressurized - **CCW**

Reverse Rotation
Viewed from Shaft End
Port A Pressurized - **CCW**
Port B Pressurized - **CW**



* For LSV option the dimension L is 3 mm [.118 in] greater.

DIMENSIONS AND MOUNTING DATA

HWSR - Wheel mount, relief valves

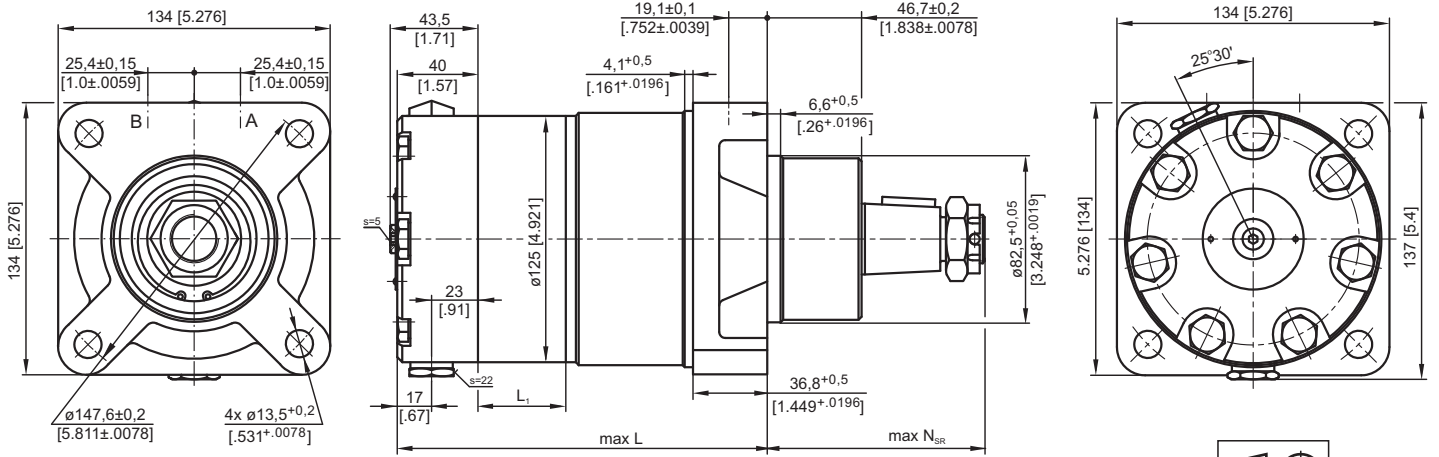

HWFR - Wheel mount, six holes, relief valves

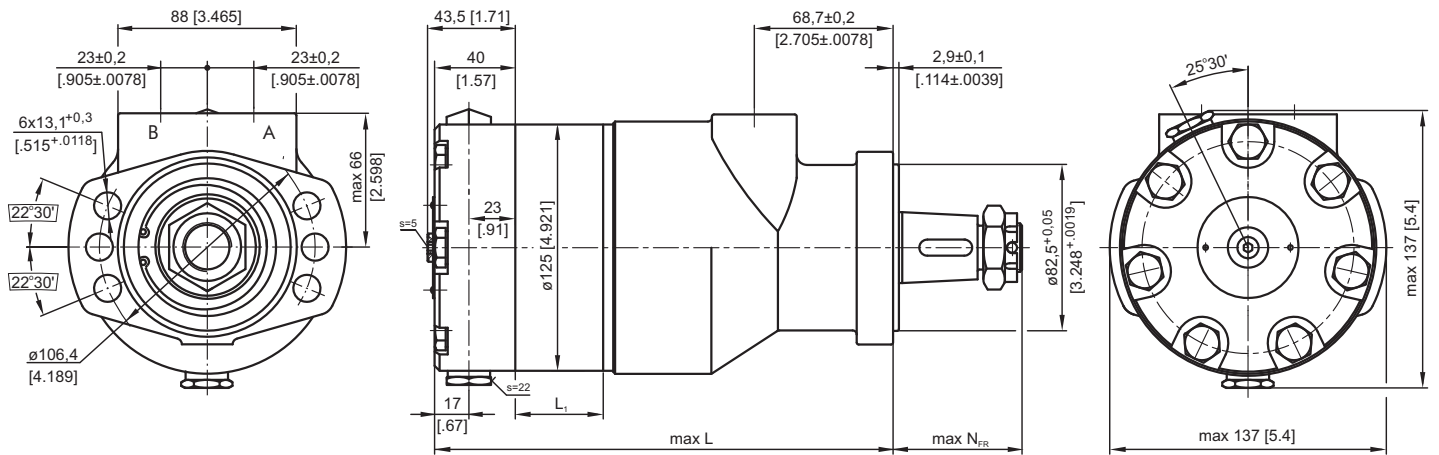

▽ - Motor Mounting Surface

	Versions	
	2	4
P _(A,B)	2xG ¹ / ₂	2x ¹ / ₈ -14UNF, O-ring

Note: For N_{FR} and N_{SR} see pages 117 and 118.

Standard Rotation
Viewed from Shaft End
Port A Pressurized - CW
Port B Pressurized - CCW

Reverse Rotation
Viewed from Shaft End
Port A Pressurized - CCW
Port B Pressurized - CW

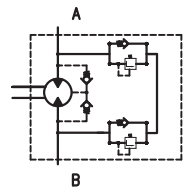

Type	*L, mm [in]		L ₁ , mm [in]
	HWSR	HWFR	
HW... 125	158,5 [6.24]	202,0 [7.95]	17,4 [0.68]
HW... 160	163,0 [6.42]	206,5 [8.13]	21,8 [0.86]
HW... 200	169,0 [6.65]	212,5 [8.37]	27,8 [1.09]
HW... 235	173,5 [6.83]	217,0 [8.54]	32,5 [1.28]
HW... 250	176,0 [6.93]	219,5 [8.64]	34,8 [1.37]
HW... 300	182,5 [7.19]	226,0 [8.89]	41,4 [1.63]
HW... 315	184,5 [7.26]	228,0 [8.98]	43,5 [1.71]
HW... 350	189,0 [7.44]	232,5 [9.15]	48,0 [1.89]
HW... 370	192,0 [7.56]	235,5 [9.27]	51,0 [2.01]
HW... 400	196,0 [7.72]	239,5 [9.43]	54,8 [2.16]
HW... 470	206,0 [8.11]	249,5 [9.82]	65,0 [2.56]
HW... 500	210,5 [8.29]	254,0 [10.00]	69,4 [2.73]
HW... 535	215,0 [8.46]	258,8 [10.19]	74,1 [2.92]
HW... 550	217,0 [8.54]	260,5 [10.26]	76,0 [2.99]

**Pressure Settings at Flow Q=5 lpm [1.32 GPM]
32 mm²/s [150 SUS]; 50°C [122°F]**

- 1 - 70 bar [1015 PSI]
- 2 - 100 bar [1450 PSI]
- 3 - 140 bar [2030 PSI]
- 4 - 170 bar [2470 PSI]
- 5 - 210 bar [3050 PSI]

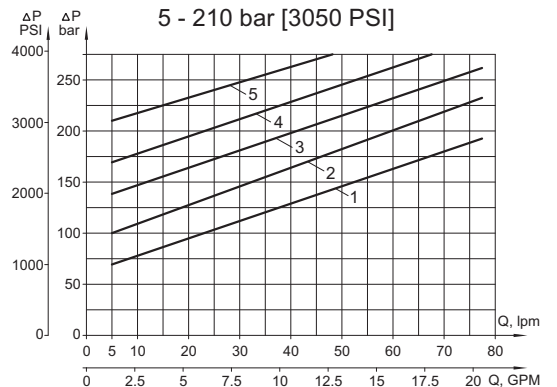

* For LSV option the dimension L is 3 mm [0.118 in] greater.

DIMENSIONS AND MOUNTING DATA

D Wheel Mount

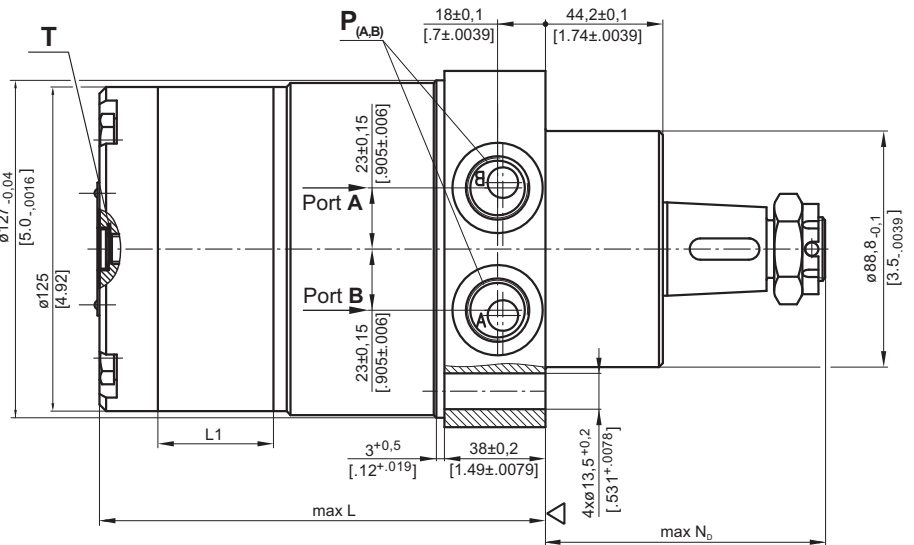
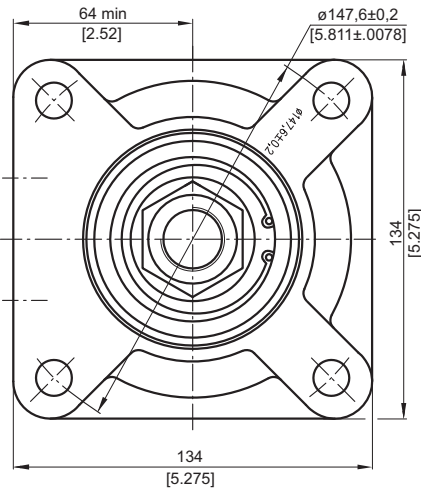

Versions		
	2	4
P_(A,B)	2xG½	2x¾-14UNF, O-ring
T	G ¼	¾-20UNF, O-ring

* For LSV option the dimension **L** is 3 mm [0.118 in] greater.

Type	*L, mm [in]		L ₁ , mm [in]
	HWD	HWV	
HW... 125	142,0 [5.59]	140,5 [5.53]	17,4 [0.68]
HW... 160	147,0 [5.79]	145,0 [5.71]	21,8 [0.86]
HW... 200	153,0 [6.02]	151,0 [5.94]	27,8 [1.09]
HW... 235	158,0 [6.22]	155,5 [6.12]	32,5 [1.28]
HW... 250	160,0 [6.30]	158,0 [6.22]	34,8 [1.37]
HW... 300	166,5 [6.56]	164,5 [6.46]	41,4 [1.63]
HW... 315	169,0 [6.65]	166,5 [6.56]	43,5 [1.71]
HW... 350	173,5 [6.83]	171,0 [6.73]	48,0 [1.89]
HW... 370	176,5 [6.95]	174,0 [6.85]	51,0 [2.01]
HW... 400	180,0 [7.09]	178,0 [7.01]	54,8 [2.16]
HW... 470	190,5 [7.50]	188,0 [7.40]	65,0 [2.56]
HW... 500	194,5 [7.66]	192,5 [7.58]	69,4 [2.73]
HW... 535	199,5 [7.85]	197,0 [7.76]	74,1 [2.92]
HW... 550	201,5 [7.93]	199,0 [7.83]	76,0 [2.99]

Note: For N_D and N_V see pages 117 and 118.

▽ - Motor Mounting Surface



Standard Rotation
Viewed from Shaft End
Port A Pressurized - **CW**
Port B Pressurized - **CCW**

Reverse Rotation
Viewed from Shaft End
Port A Pressurized - **CCW**
Port B Pressurized - **CW**

Versions		
	2	4
T	G ¼	¾-20UNF, O-ring

V Wheel Mount

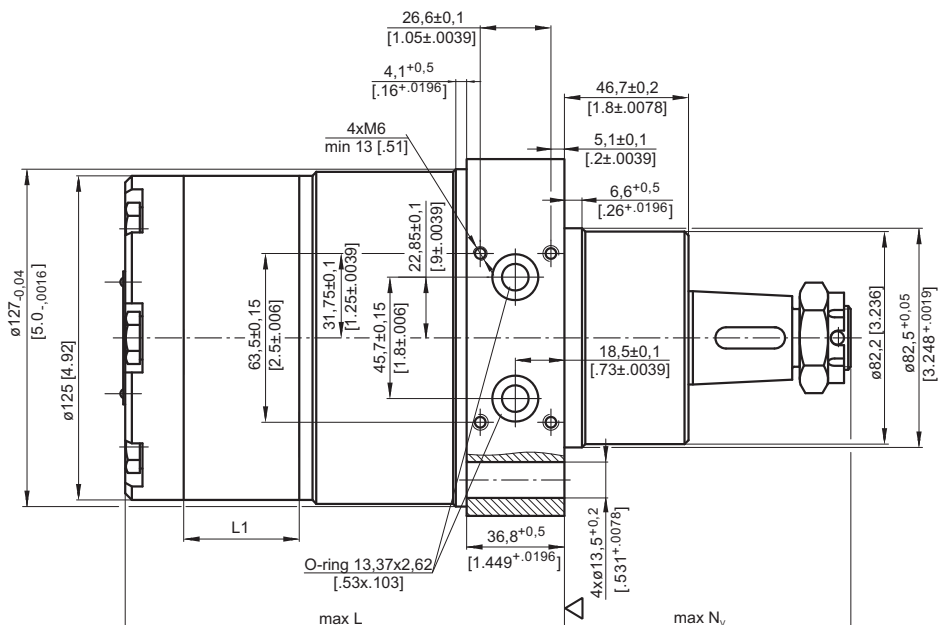
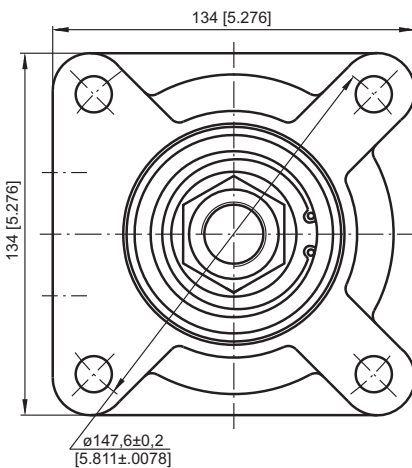

DIMENSIONS AND MOUNTING DATA

F Magneto Mount

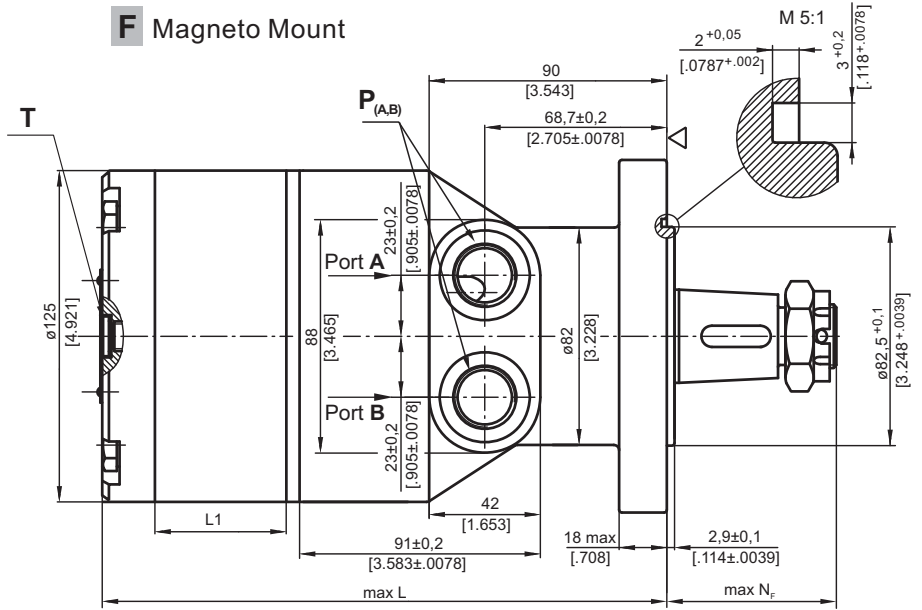
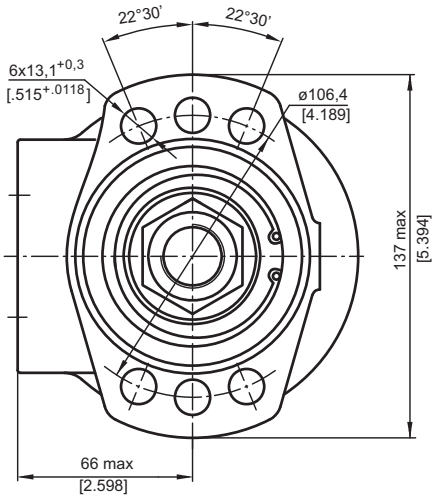

Type	*L, mm [in]	L ₁ , mm [in]
HWF(V) 125	184,0 [7.24]	17,4 [.68]
HWF(V) 160	188,5 [7.42]	21,8 [.86]
HWF(V) 200	194,5 [7.66]	27,8 [1.09]
HWF(V) 235	199,0 [7.84]	32,5 [1.28]
HWF(V) 250	201,5 [7.93]	34,8 [1.37]
HWF(V) 300	208,0 [8.20]	41,4 [1.63]
HWF(V) 315	210,0 [8.27]	43,5 [1.71]
HWF(V) 350	214,5 [8.45]	48,0 [1.89]
HWF(V) 370	217,5 [8.56]	51,0 [2.01]
HWF(V) 400	221,5 [8.72]	54,8 [2.16]
HWF(V) 470	231,5 [9.11]	65,0 [2.56]
HWF(V) 500	236,0 [9.29]	69,4 [2.73]
HWF(V) 535	240,5 [9.47]	74,1 [2.92]
HWF(V) 550	242,5 [9.55]	76,0 [2.99]

HWFV - Wheel mount, six holes, relief valves

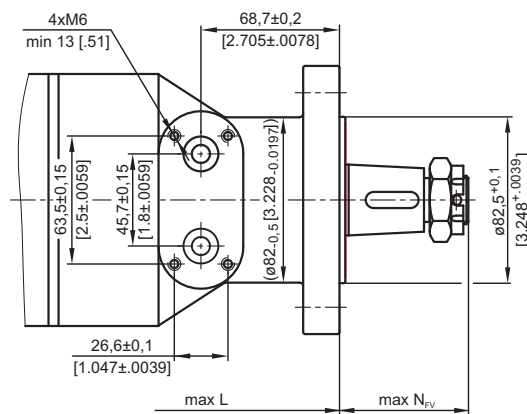

	Versions	
	2	4
P _(A,B)	2xG½	2x¾-14UNF, O-ring
T	G ¼	7/16-20UNF, O-ring



Note: For N_F and N_{FV} see pages **117** and **118**.

▽ - Motor Mounting Surface

Standard Rotation
Viewed from Shaft End
Port A Pressurized - **CW**
Port B Pressurized - **CCW**

Reverse Rotation
Viewed from Shaft End
Port A Pressurized - **CCW**
Port B Pressurized - **CW**

* For LSV option the dimension L is 3 mm [1.18 in] greater.

MAX. PERMISSIBLE SHAFT SEAL PRESSURE

HW, HWF, HWS, HWD, HWV

HW... motors with drain connection:

The shaft seal pressure equals the pressure in the drain line.

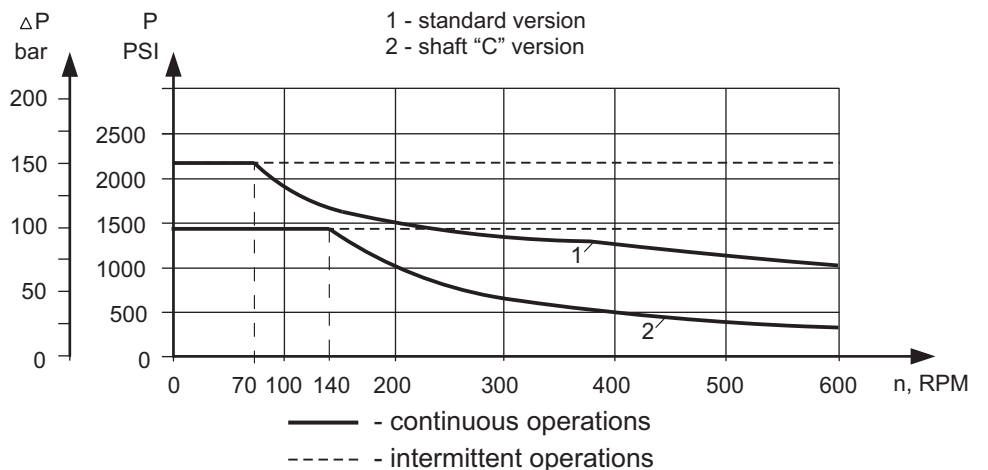
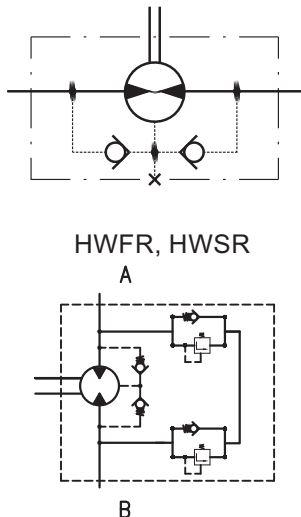

PERMISSIBLE SHAFT LOADS

HW...

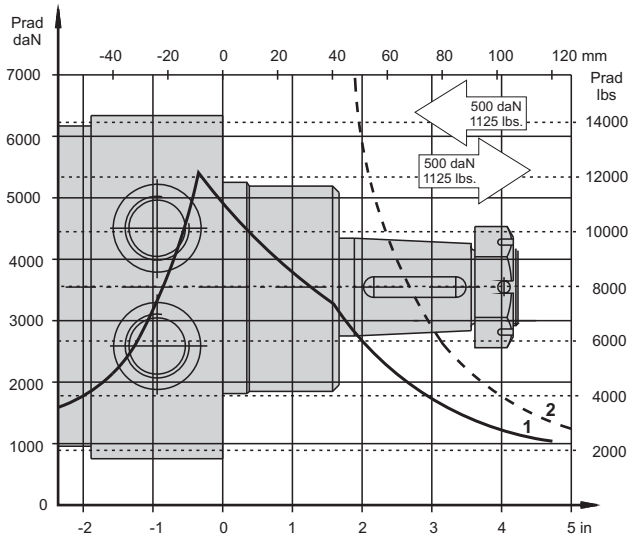

HWF...

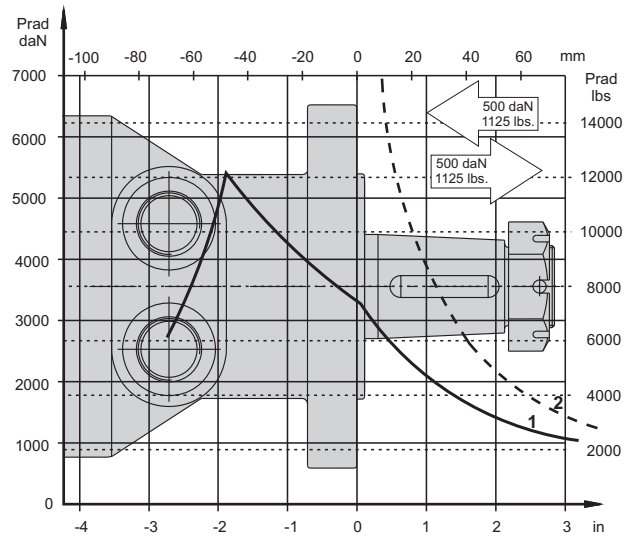

HWV...

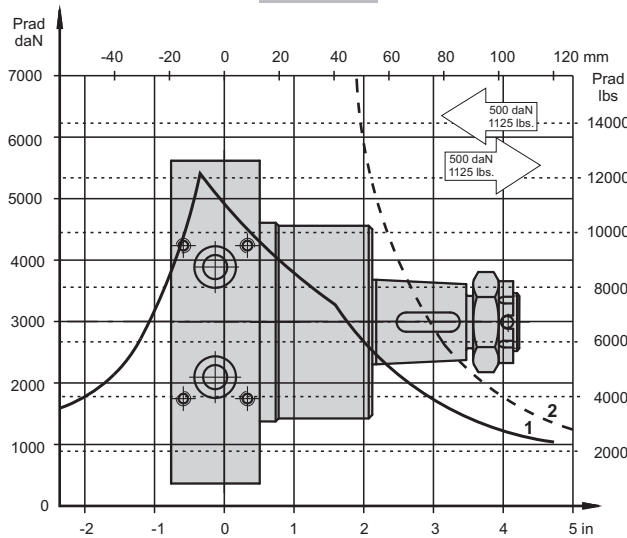

- 1 - Bearing curve: The curve applies to a B10 bearing life of 2000 hours at 100 RPM.
- 2 - Shaft curve: The curve represents Max. permissible radial shaft load with safety factor 3:1.

SHAFT EXTENSIONS

C - 1½" [38,1] straight, Parallel key ⅜"x⅜"x1½" BS46
Max. Torque 120 daNm [10630 lb-in]

CO - ø25, straight, Parallel key A8x7x32 DIN 6885
Max. Torque 40 daNm [3540 lb-in]

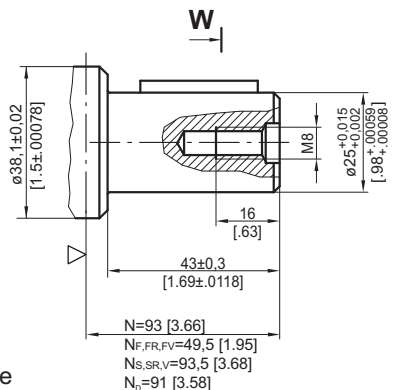
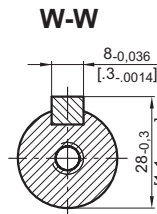
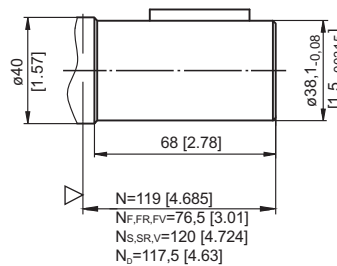
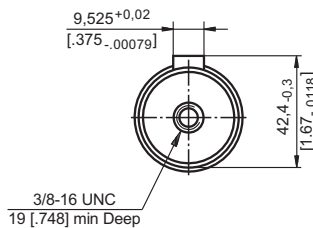

- N - for standard flange
- N_F - for F flange
- N_{FR} - for FR flange
- N_{FV} - for FV flange
- N_S - for S flange
- N_{SR} - for SR flange
- N_D - for D flange
- N_V - for V flange

▽ - Motor Mounting Surface



SHAFT EXTENSIONS [continued]

K - 1 1/4" straight, Parallel key 5/16"x5/16"x 1 1/2" BS46
Max. Torque 77 daNm [6815 lb-in]

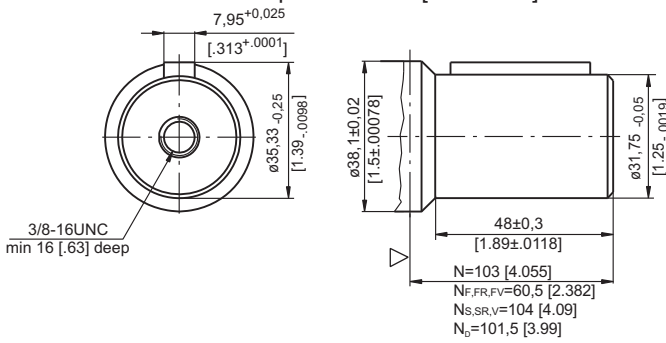

M - ø32 straight, Parallel key A10x8x32 DIN 6885
Max. Torque 77 daNm [6815 lb-in]

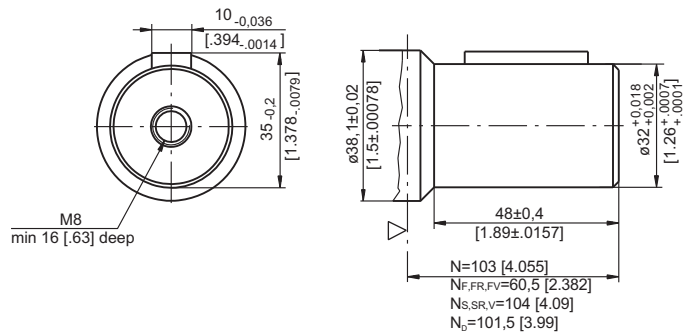

L - ø1 1/4" splined 14T, DP12/24 ANSI B92.1-1976 Norm
Max. Torque 95 daNm [8410 lb-in]

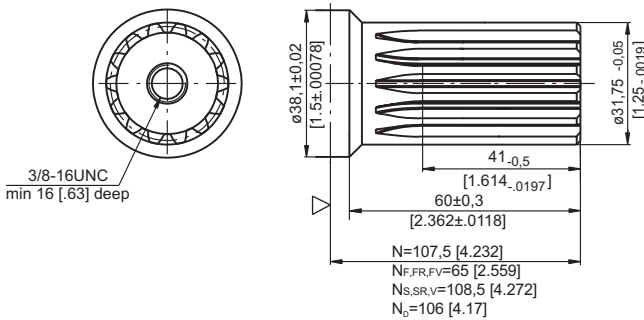

KB - ø35 tapered 1:10, Parallel key 5/16"x5/16"x1 1/4" BS46
Max. Torque 95 daNm [8410 lb-in]

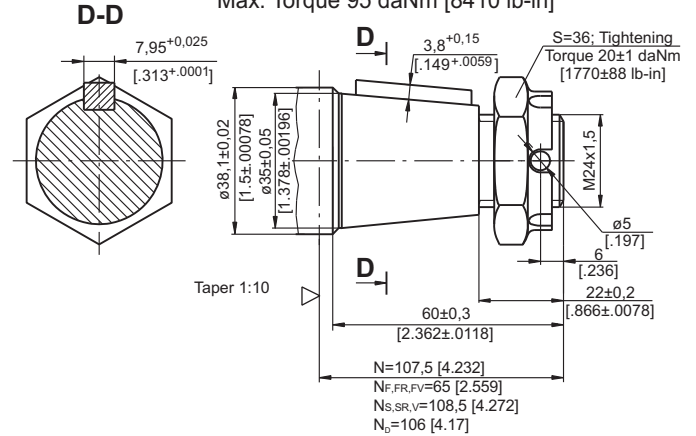

T - 1 1/2" tapered 1:8, Parallel key 5/16"x5/16"x1 1/4" BS46
Max. Torque 120 daNm [10620 lb-in]

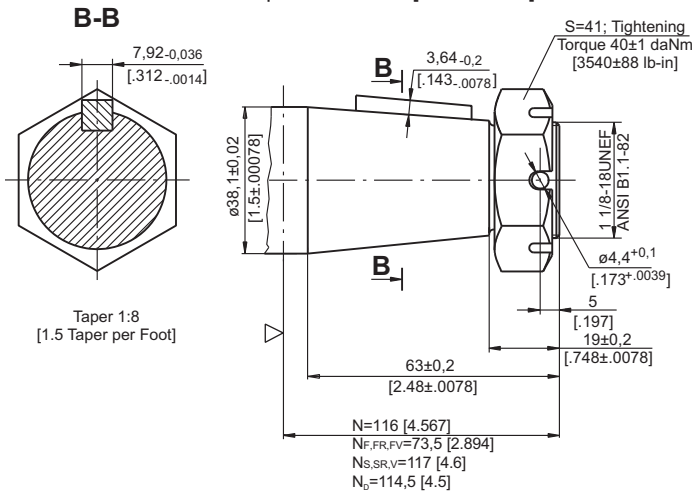

R - 1 1/4" tapered 1:8, Parallel key 5/16"x5/16"x1" BS46
Max. Torque 77 daNm [6815 lb-in]

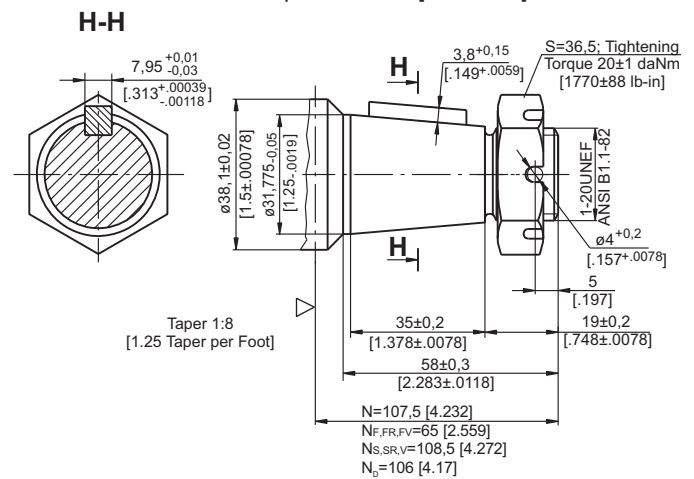

SH - ø1" splined BS 2059, SAE 6B
Max. Torque 40 daNm [3540 lb-in]

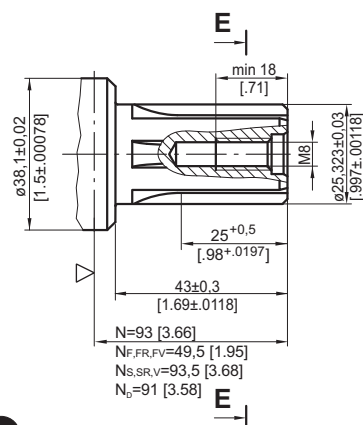
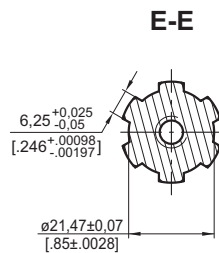

▽ - Motor Mounting Surface

- N - for standard flange
- N_F - for F flange
- N_{FR} - for FR flange
- N_{FV} - for FV flange
- N_S - for S flange
- N_{SR} - for SR flange
- N_D - for D flange
- N_V - for V flange

ORDER CODE

	1	2	3	4	5	6	7	8	9
HW							/		

Pos.1 - Mounting Flange

	omit	- Wheel mount, four holes
E	- Wheel mount, four holes, rear ports	
F	- Oval mount, six holes	
FR	- Oval mount, six holes, relief valves	
FV	- Oval mount, six holes, relief valves	
FE	- Oval mount, six holes, rear ports	
S	- Wheel mount, four holes	
SR	- Wheel mount, four holes, relief valves	
SE	- Wheel mount, four holes, rear ports	
D	- Wheel mount, four holes; mounting on $\varnothing 88,8$ [3.5]	
V^{1)*}	- Wheel mount, four holes, valves	

Pos.2 - Displacement code

125	- 126,0 cm ³ /rev [7.69 in ³ /rev]
160	- 158,0 cm ³ /rev [9.64 in ³ /rev]
200	- 201,3 cm ³ /rev [12.28 in ³ /rev]
235	- 235,0 cm ³ /rev [14.33 in ³ /rev]
250	- 252,0 cm ³ /rev [15.37 in ³ /rev]
300	- 300,0 cm ³ /rev [18.30 in ³ /rev]
315	- 314,9 cm ³ /rev [19.21 in ³ /rev]
350	- 347,8 cm ³ /rev [21.21 in ³ /rev]
370	- 369,0 cm ³ /rev [22.51 in ³ /rev]
400	- 396,8 cm ³ /rev [24.20 in ³ /rev]
470	- 470,6 cm ³ /rev [28.71 in ³ /rev]
500	- 502,4 cm ³ /rev [30.65 in ³ /rev]
535	- 536,0 cm ³ /rev [32.70 in ³ /rev]
550	- 550,0 cm ³ /rev [33.55 in ³ /rev]

Pos.3 - Shaft Extensions^{2)*}

K	- 1 1/4" [31,75] straight, Parallel key $\frac{5}{16}$ "x $\frac{5}{16}$ "x1 1/2" BS46
KB	- $\varnothing 35$ tapered 1:10, Parallel key $\frac{5}{16}$ "x $\frac{5}{16}$ "x1 1/4" BS46
L	- 1 1/4"[31,75] splined 14T, ANSI B92.1-1976
M	- $\varnothing 32$ straight, Parallel key A10x8x32 DIN 6885
R	- 1 1/4"[31,75] Tapered 1:8, Parallel key $\frac{5}{16}$ "x $\frac{5}{16}$ "x1 1/4" BS46
T	- 1 1/2"[38,1] Tapered 1:8, Parallel key $\frac{5}{16}$ "x $\frac{5}{16}$ "x1 1/4" BS46
C	- 1 1/2" [38,1] straight, Parallel key $\frac{3}{8}$ "x $\frac{3}{8}$ "x1 1/2" BS46
CO	- $\varnothing 25$, straight, Parallel key A8x7x32 DIN 6885
SH	- $\varnothing 1$ " splined BS 2059, SAE 6B

Pos.4 - Ports

2	- side ports, 2xG1/2, G1/4, BSP thread, ISO 228
4	- side ports, 2x7/8-14 UNF, O-ring, 7/16-20 UNF
5^{3)*}	- rear ports, 2xG3/8, G1/4, BSP thread, ISO 228
6^{3)*}	- rear ports, 2x9/16-18 UNF, O-ring, 7/16-20 UNF

Pos.5 - Special Features^{4)*, 5)*, 6)*} [see page 120]

Pos.6 - Valves Pressure Range, bar^{7)*}

/	- 70, 100, 140, 170, 210
---	--------------------------

Pos.7 - Design Series

	- omit - Factory specified
--	----------------------------

NOTES:

- 1)* Flange **V** is for versions 2 and 4 - drainage only!
- 2)* The permissible output torque for shafts must not be exceeded!
- 3)* For **E**-version only!
- 4)* If the code on pos.5 is not specified in the order, it will be considered as LL-option.
- 5)* Colour at customer's request.
- 6)* Non painted feeding surfaces, colour at customer's request.
- 7)* For **SR** and **FR** only!

E-version is not available with **SR** and **FR**!!!

The hydraulic motors are mangano-phosphatized as standard.