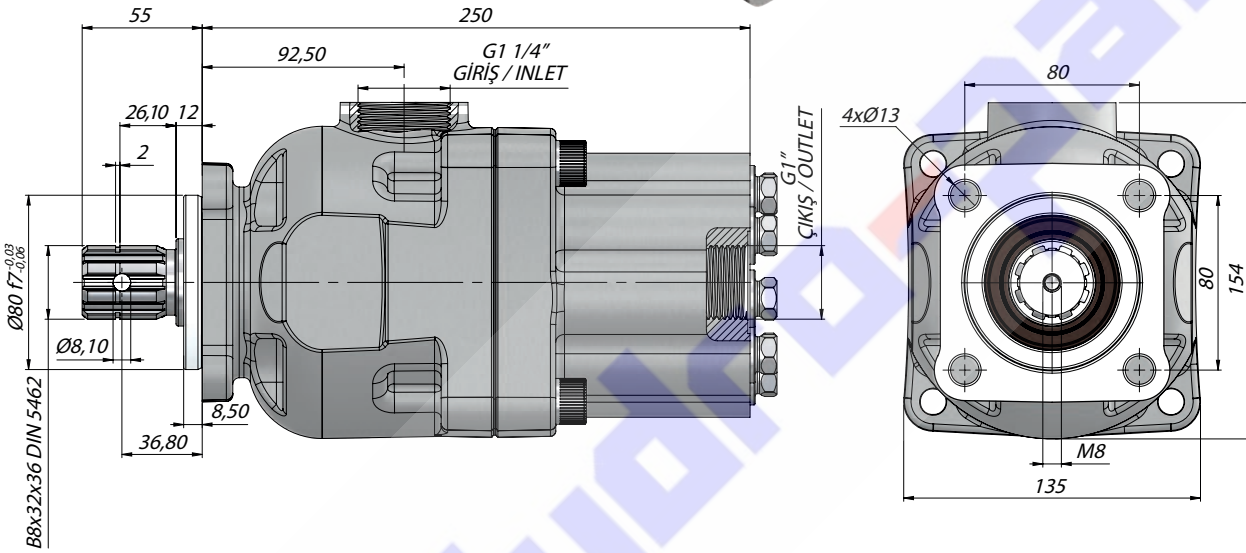

TEKNİK VERİLER | TECHNICAL DATA
4 DELİKLİ ISO PİSTONLU POMPA | 4 HOLES ISO PISTON PUMP

HİDROLİK SEMBOL
HYDRAULIC SYMBOL

A SERİSİ BURÇLU ÇELİK KRANK | A SERIES BUSH STEEL CRANK

Kod Code	İletim Hacmi Displacement	Maks.Sürekli Basınç Max.Continuous Pressure	Maks.Aralıklı Basınç Max.Intermittent Pressure	Maks.Anlık Basınç Max.Peak Pressure	Maks.Sürekli Hız Max.Continuous Speed	Min. Hız Min.Speed
	(cm ³ /rev)	(100%)(BAR)	(20 sec.max.)(BAR)	(6 sec.max.)(BAR)	(RPM)	(RPM)
P0960SF131A	60	270	285	300	1500	300
P0980SF131A	80					

B SERİSİ RULMANLI DÖKÜM KRANK | B SERIES BEARING CASTING CRANK

Kod Code	İletim Hacmi Displacement	Maks.Sürekli Basınç Max.Continuous Pressure	Maks.Aralıklı Basınç Max.Intermittent Pressure	Maks.Anlık Basınç Max.Peak Pressure	Maks.Sürekli Hız Max.Continuous Speed	Min. Hız Min.Speed
	(cm ³ /rev)	(100%)(BAR)	(20 sec.max.)(BAR)	(6 sec.max.)(BAR)	(RPM)	(RPM)
P0960SF131B	60	270	285	300	1500	300
P0980SF131B	80					

C SERİSİ RULMANLI ÇELİK KRANK | C SERIES BEARING STEEL CRANK

Kod Code	İletim Hacmi Displacement	Maks.Sürekli Basınç Max.Continuous Pressure	Maks.Aralıklı Basınç Max.Intermittent Pressure	Maks.Anlık Basınç Max.Peak Pressure	Maks.Sürekli Hız Max.Continuous Speed	Min. Hız Min.Speed
	(cm ³ /rev)	(100%)(BAR)	(20 sec.max.)(BAR)	(6 sec.max.)(BAR)	(RPM)	(RPM)
P0960SF131C	60	270	285	300	1500	300
P0980SF131C	80					